



规格书

Customer
客 户: _____
Product
品 名: 8 寸 LCM
Part No.
型 号: SHX-C080-01
Panel
LCD 屏: CPT8 寸数字屏
Date
日 期: 2013-11-04

Approved 批准	check 审核	prepare 作成

三和鑫(香港)有限公司

地址: 深圳市宝安区新安六路勤业商务中心 A 座 522 室

电话: 0755-23057826/13927411766



一、目 录

项目	内容	页次
	封面	1
一	目录	2
二	变更记录	2
三	电路图	3
四	光电特性	3
五	光学测量规定	4
六	品质检验标准	5
七	产品寿命	6
八	信赖性试验	6
九	不合格品补偿	7
十	防静电要求	7
十一	敬告客户	7
十二	机密文件	8
十三	安全性	8
十四	其它	8
十五	光电测试报告	9
十六	外形尺寸	10
十七	玻璃规格书	

二、变更记录

日期	内容	版次	负责人
13-11-04	首次发行	V0	



三、电路图:

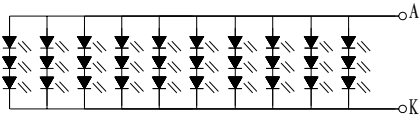

Backlight LED Circuit (3串10并 = 30 LED)

四、光电特性

4.1 LED 光源特性图。

■ Forward Voltage vs. Forward Current

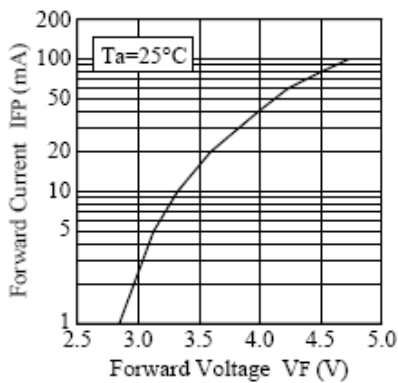

■ Forward Current vs. Relative Luminosity

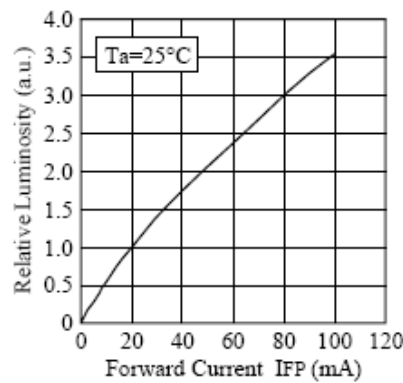

■ Duty Ratio vs. Allowable Forward Current

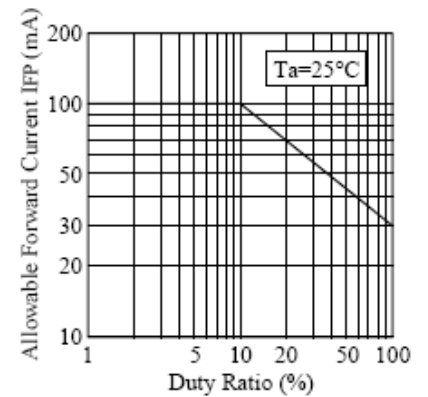

■ Ambient Temperature vs. Forward Voltage

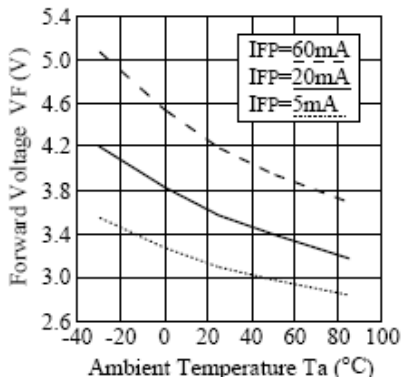

■ Ambient Temperature vs. Relative Luminosity

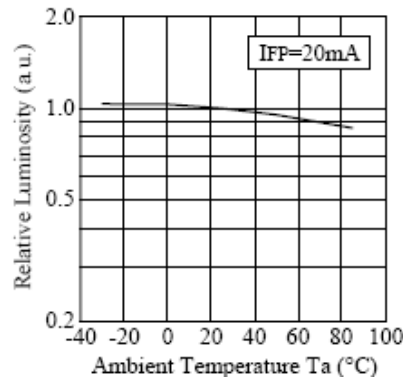

■ Ambient Temperature vs. Allowable Forward Current

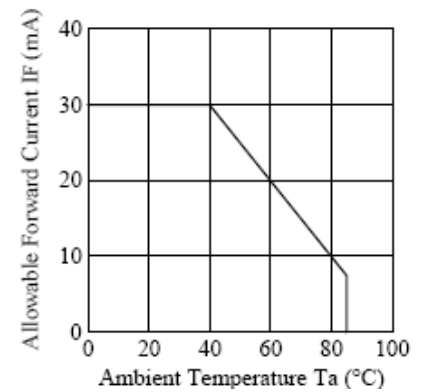

4.2 背光源光电特性

项目 (Item)	符号 (Symbol)	测定条件 (Condition)	最小值 (min.)	典型值 (typ.)	最大值 (max.)	单位 (Unit)
正向电压(Forward Voltage)	Vf	If= 200 mA	8.7	9.6	10.5	V
坐标 (Colour Coordinate)	X		TBD		TBD	
	Y		TBD		TBD	
均匀性 (Uniformity)	△Iv		70	75		%
亮度(9点均值)背光 BL (Luminance)	Lv					cd/m ²
亮度(9点均值)模组 LCM (Luminance)	Lv			300	cd/m ²	

均匀性计算方法: 9点辉度值之(最小辉度/最大辉度)X100%值



4.3 背光源极限参数

项目 Item	符号 Symbol	条件 Conditions	值 Rating	单位 Unit
极限直流正向电流 Absolute maximum forward current	Ifm	—	300	mA
脉动驱动时极限正向电流 Peak forward current	Ifp	1msec 脉动, 1/10 占空比 1msec Pius 10%Duty Cycle	600	mA
极限功耗 Power dissipation	Pd	—	3150	mW
工作温度 Operating Temperature Range	Topr	—	-20~+60℃	℃
贮存温度 Storage Temperature Range	Tstg	—	-30~+70℃	℃

当工作温度高于 25℃时, Ifm(极限直流正向电流)、Ifp(脉冲驱动时极限正向电流)、Pd(极限功耗)都必须降低)。Ifm(极限直流正向电流)降低率是-0.36/LED mA/℃; Ifp(脉冲驱动时极限正向电流)降低率是-0.86/LED mA/℃; Pd(极限功耗)降低率是-0.75/LED mW/℃; 产品的工作电流不能大于对应工作温度条件下的 Ifm(极限直流正向电流)或 Ifp(脉冲驱动时极限正向电流)的 60%。

5、光学测量规定:

5.1 测试仪器及方法 (见下图)

5.2 测试条件:

1) 测试设备: TOPCON BM-7A

机器误差: 亮度±5%, 色坐标±0.005.

2) 观测角度: 1°

3) 稳定时间:

LED 背光源点亮 1 分钟后测定; CCFL 背光源点亮 3 分钟后测定

4) 测试环境

环境温度: +25℃±3℃; 环境湿度: 60%RH±20%RH; 环境亮度: 暗室 (10 LUX 以下)

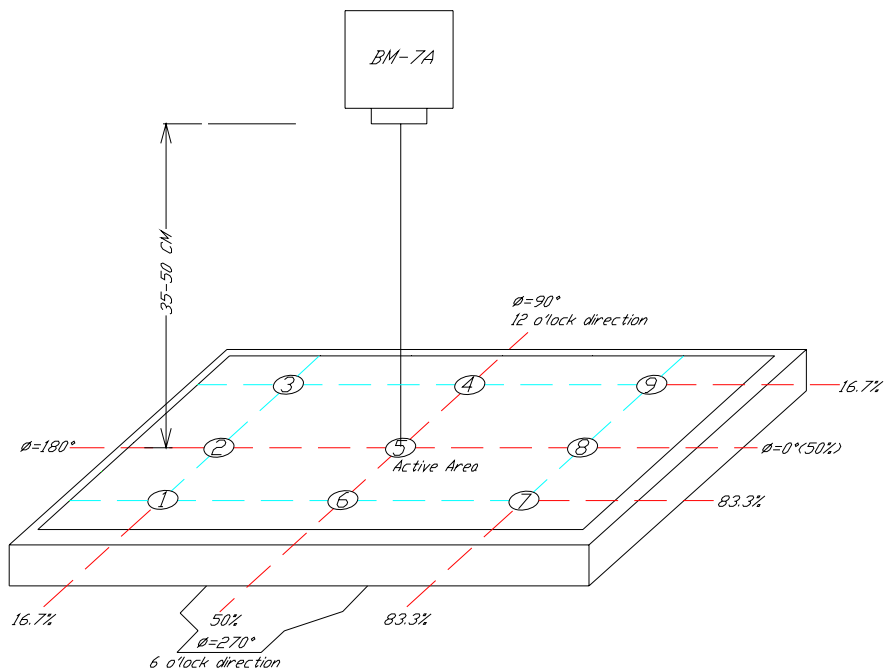



六、品质检验标准

6.1 出货检查规定

- 1)、批量的定义：原则上同一日所制造之背光源视为一批次 (LOT)，出货时以每一批次为单位进行检查。
- 2)、检查方法：MIL-STD-105E (GB/T2828-87)
- 3)、抽样水准：II

6.2 检查项目

No.	检查项目	合格条件	检查条件
1	外观	轻不良 AQL: 1.0% 重不良 AQL: 0.4% 致命不良 c=0	见 5 页 7.3 外观检查规格表 按抽样方案执行, MIL-STD-105E
2	构造、寸法 (重不良)	n=5 c=0 (抽样 5pcs)	按图纸, 测量长、宽、厚度、出线长
3	光学的特性 (重不良)	n=5 c=0 (抽样 5pcs)	见 3 页 5.2 背光源光电特性表

检查规格分类表:

CR (严重) AC→0; RE→1	MA (主要) AQL: 0.4%	MI (次要) AQL: 1.0%
1、背光源不亮 2、背光源散架	1、可视区光学膜片 (Film) 偏移、翘曲、浮点、变形。 2、光学特性, 包括辉度、均匀性、色度。 3、管制尺寸, 指组装液晶成品不可发生干涉的重点尺寸。 4、混料。 5、可视区塑胶框毛边; 可视区漏光; 可视区黑影; 可视区点状缺陷; 可视区线状缺陷; 可视区线状缺陷。 6、B/L 不亮。	1、铁框变形、刮痕、打痕、油污、毛边、生锈; 铁框扣位未扣紧; 背板绝缘膜未贴合。 2、塑胶框外观不良。 3、螺丝未锁紧、滑牙、螺孔毁损、未攻牙、偏移。 4、外包装箱胶带类的偏移、浮起。 5、无序号标签、批号标示不清楚。 6、短装 (包装数量)。

6.3 外观检查表

1)、点灯外观

点灯外观规格如下：以组装完成的背光源为准。检验距离：发光面法线方向 $30 \pm 5\text{cm}$

No.	项目	规格
1	黑点、黑不均 白点、白不均 异物 (点状)	直径(D) $\phi \leq 0.2\text{mm}$, 不计; $0.2 < \phi \leq 0.3\text{mm}$, 3 个可过, 任两点距离不可小于 10mm; $\phi \geq 0.3\text{mm}$, 不可有。 
2	异物 (线状)	$W \leq 0.02\text{mm}$, 不计 $0.02 < W \leq 0.03\text{mm}$, $L \leq 5.0\text{mm}$, 3 处可过 $0.03 < W \leq 0.05\text{mm}$, $L \leq 3.0\text{mm}$, 1 处可过 $W > 0.05\text{mm}$, 以点状式判定 
3	异常发光 牛顿环	亮眼、轻微发光不均匀 (一半黄, 一半蓝), 以客户承认样板为接收标准; 牛顿环盖上 LCD Panel 不可有

备注:

- a) 两个 $\phi 0.10$ 以下的黑点及亮度需相距 10mm 以上。
- b) 以上规格包含扩散膜上之浓黑点。
- c) 判定有困难时以盖上 Panel 判定 (转动背光源上下 $\pm 45^\circ$, 左右 $\pm 60^\circ$ 。)
- d) 检查时加以振动及以空气吹, 确认无不良。



2)、非点灯的外观

项目	规格
膜片	逆翘不可有;扩散膜,增光膜正翘,拱起不能超出 1.0mm;反射膜拱起不能超过 2.0mm;不过有龟裂,缺角,破孔现象;不可有受重压扭曲变形,受热扭曲变形现象;表面脏污,胶粘物不可有(保护膜除外)。
线材、端子线	线材焊接端不可分叉,导线绝缘皮不可破损露线芯,热塑套管不可破损;端子不得脱落,于管轴方向可抵抗 11.76N (1.2kgf/sec) 静负荷;极性不可接反(A为正极,K为负极)。
塑胶框	不可有龟裂,不可有缺胶;注胶口残料不得高于胶框有效平面;不可有油垢,脏污,胶粘物;毛边,溢边不能影响 LCD 模组组装作业。
铁框	表面刮花: W(Width)宽, L(Length)长;范围: 50x50mm 平方内, 0.1<W≤0.2mm, L≤10.0mm 允许 8 条 0.1<W≤0.2mm, 10.0≤L≤20.0mm 允许 4 条 无感刮伤不计, W<0.05mm 不计; 表面凹点: Φ圆之直径,范围: 50x50mm 平方内, Φ≤0.3mm 不计, 0.3≤Φ≤0.5mm 允许 2 点 Φ≥0.5mm 不允许 表面油垢,脏污,胶粘物不可有,锈斑不可有。
平整度	L≤100mm, C≤0.5mm; L>100mm, C≤1.0mm

备注:

- 1) 目视距离: 30cm; 检验角度: 上下±35°, 左右±45°。
- 2) 针对无感刮伤及原素材不良之部分, 最终依双方所签订之限度样板为依据。

七、产品寿命

周围温度+25℃±2℃, 湿度 60±20%RH, 以每灯 20mA 工作电流之推荐使用条件, 背光源之寿命为:

辉度减半平均寿命: 30,000 小时以上

辉度减半保证寿命: 20,000 小时以上

注: 辉度减半平均寿命指背光源平均辉度衰减到初期平均辉度的 50%所需时间。

八、信赖性试验

8.1 寿命试验

试验项目	检验方法	判定
1. 高温高湿放置试验	温度+60℃, 湿度 90%RH 240Hrs	试验后, 须常温放置 2 小时, 在 24 小时后测定。 1. 亮度衰减在 20%以内, 电压≤±5%。 2. 外形尺寸变化仍在规格以内。 注: 马口铁, 镀铝锌板铁框在高湿、吸潮的情况下易生锈, 生锈不列入判定项目。
2. 低湿放置试验	温度-30℃, 常湿 240Hrs	
3. 高温放置试验	温度+70℃, 常湿 240Hrs	
4. 高温高湿操作试验	温度+60℃, 湿度 90%RH 240Hrs	
5. 低温操作试验	温度-20℃, 常湿 240Hrs	
6. 高温操作试验	温度+60℃, 常湿 240Hrs	
7. 冷热冲击试验	-20℃ → +25℃ → +70℃ (30min) → (5min) → (30min) 200Cycles	

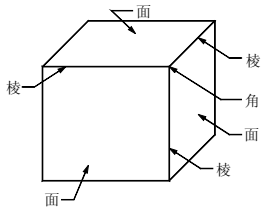

8.2 机械环境测试

试验项目	检验方法	时间	判定
跌落试验	H=60cm 自由落下： 从七个方向：相邻的三个面、三条棱、一个角 	首次量产及包装方式、材料变更时。	1. 试验后-----外观及机能判定： a. 异物混入（产品表面可接受）、刮伤、位置偏移、零件脱落、凹凸伤痕、折痕，不可有。 b. 不点灯或点灯异常（闪烁变色半亮）之非正常点灯现象不可有。 c. 机械性及物理性之损害（部材破损、外观变形、嵌合不良）不可有。 d. 落下试验后，包外箱不可有破裂之现象。 2. 判定基准 a. 点灯无问题。 b. 外观无异常变化。 c. 外观无损坏、破裂伤痕等情形。
振荡试验	幅度 1.5mm 频率 10~55Hz，相邻三个面每面各 15 分钟		外观：产品无缺损，脱落等外观不良。 发光：不可有不发光及点亮闪烁。
引线拉伸强度	于管轴方向可抵抗 11.76N (1.2kgf/sec) 静负荷		
端子拉伸强度	于管轴方向可抵抗 11.76N (1.2kgf/sec) 静负荷		
底盖螺栓孔承受扭力	1.5kgf · cm		

九、不合格品补偿

- 9.1 由贵公司检查若发现有不合格品时，请尽快通知本公司，以便双方进行检讨，决定处置方案。
- 9.2 若不合格品的起因是制造所致，则免费更换该成品。

十、防静电要求

- 10.1 本产品对静电十分敏感，接触产品时须注意；在有超过产品额定最大值(2KV)的瞬间高压下，会对产品造成伤害破坏。
- 10.2 防静电措施应做到身体接地，戴防静电手环，指套，穿防静电衣服，鞋等。
- 10.3 所有机器，设备必须接地，在静电容易产生的场所，最好使用离子风机。
- 10.4 在产品的一系列组装过程中，都应采取防静电措施。

十一、敬告客户

- 11.1 如果本产品所使用的铁框是马口铁，该材料表面是没有经过防锈处理，如暴露于高温、潮湿的空气中极易氧化生锈；如果产品使用的是镀铝锌板材质，其材料表面虽有镀铝锌层保护，有一定的防锈功能，但其切口（边）也容易生锈；马口铁和镀铝锌板材料本身无法通过盐雾试验；
- 11.2 防止马口铁、镀铝锌板氧化生锈比较可行的办法是置于密封、干燥的环境，温湿度要求是：温度≤35℃，湿度≤45%RH. 我司产品出货时都有塑胶袋密封包装，拆封后 3-5 天内必须完成装机或重新密封保存，否则容易氧化生锈；
- 11.3 基于马口铁、镀铝锌板材质都有生锈的可能，如贵司对铁框外观有特别要求，或表面不允许氧化生锈等，请在确认前将相关信息告知我司，以便选用符合贵司要求的相关材质。



十二、机密文件

相互注意有关本产品规格的情报档案、图面内容等，不可透露给不相关的单位及个人

十三、安全性

- 13.1 本产品制造工程中所选材料均是取得环保认证的无害物质，符合欧盟规定的“RoHS”标准；
- 13.2 以不会发生火灾的材料制造而成。

十四、其它

- 14.1 对本承认书，如有任何问题点，经双方协议后处理。
- 14.2 任何变更都必须经过联络，并取得彼此同意后方可变更，并针对变更内容记录管理。
- 14.3 本产品保证期限自出厂日起一年。



十五、光电测试报告

测试条件:

1. 测试设备: TOPCON BM-7A

机器误差: 亮度±5%, 色坐标±0.005.

2. 观测角度: 1°

3. 稳定时间:

LED 背光源点亮 1 分钟后测定;

CCFL 背光源点亮 3 分钟后测定

4. 测试环境:

环境温度: +25°C ± 3°C ;

环境湿度: 60%RH ± 20%RH ;

环境亮度: 暗室 (10 LUX 以下)

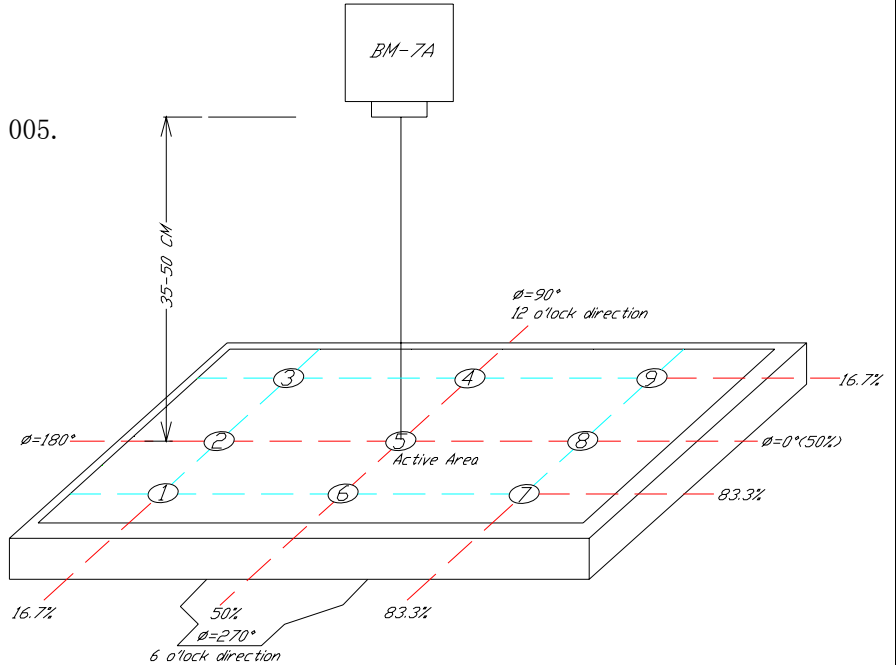

亮度 样品 测试点	额定电流 (200) mA							
	背光 1#	模组 1#	背光 2#	模组 2#	背光 3#	模组 3#	背光 4#	模组 4#
TP1	5833	306						
TP2	5510	291						
TP3	5282	277						
TP4	5890	308						
TP5	6175	317						
TP6	5567	293						
TP7	5852	308						
TP8	6156	319						
TP9	5472	289						
Xcoordinate								
Ycoordinate								
△Lv(cd/m2)	5749	301						
均匀性 (%)	86	87						
Vf (V)	9.3	9.3						

均匀性计算公式:

$$\text{亮度均匀性} = \frac{9 \text{ 点最小值}}{9 \text{ 点最大值}} \times 100\%$$



十六、外形尺寸

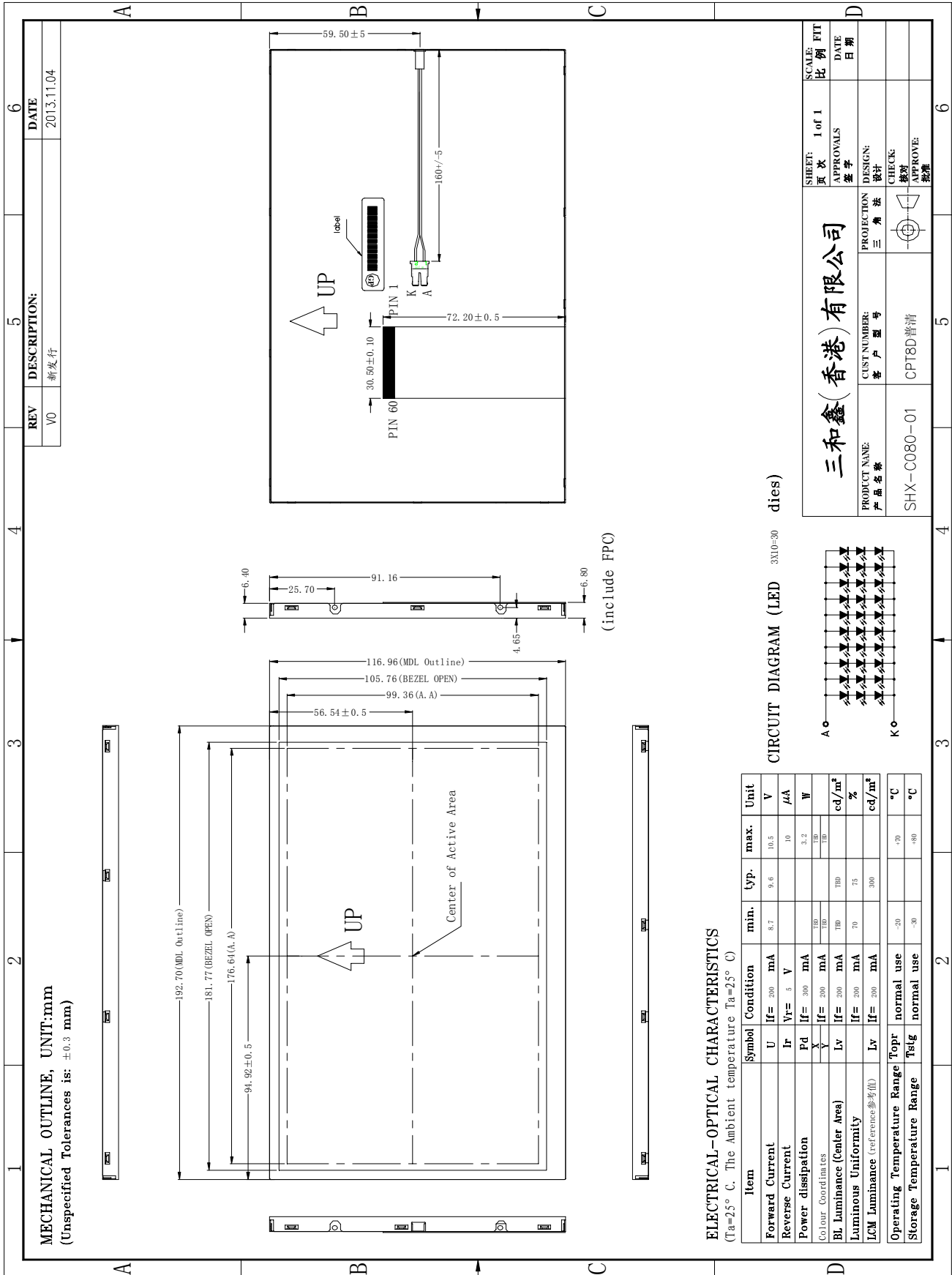



十七、玻璃规格书



Chunghwa Picture Tubes, Ltd. Technology Specification

To : 晶華微
Date : 131104

TFT LCD
CLAP080LJ01CW

ACCEPTED BY : V0.0

APPROVED BY	CHECKED BY	PREPARED BY
Ronald	Herman	Andy

Prepared by :
Medium Product Planning Management General Division
Product Planning Management Center
CHUNGHWA PICTURE TUBES, LTD.

1127 Hopin Rd., Padsh, Taoyuan, Taiwan 334, R.O.C.
TEL: +886-3-3675151 FAX: +886-3-377-3858

DOC.NO:	SPEC_CLAP080LJ01CW_V0.0_晶華微_131104	Issue Date:	20130424
---------	------------------------------------	-------------	----------



CPT

CHUNGHWA PICTURE TUBES, LTD.,

REVISION STATUS

Revision Notice	Description	Page	Rev. Date
0.0	First revision (Tentative)	--	2013/03/15

Only Confidential



CONTENTS

1. OVERVIEW	4
2. ABSOLUTE MAXIMUM RATINGS.....	5
3. ELECTRICAL CHARACTERISTICS	6
3.1 Typical operation conditions.....	6
3.2 TFT-LCD Current consumption	7
3.3 Power - Signal sequence	7
3.4 Timing characteristics of input signals.....	8
4. INTERFACE CONNECTION:	11
4.1 CN1(Signal of interface).....	11
5. MECHANICAL DIMENSION.....	13
5.1 Front Side.....	13
5.2 Rear Side	14
6. OPTICAL CHARACTERISTICS	15
7. RELIABILITY TEST.....	16
8. WARRANTY	17



1. OVERVIEW

CLAP080LJ01CW is 8.0" color TFT-LCD (Thin Film Transistor Liquid Crystal Display) OLB module (finish outer lead bonding) composed of LCD panel and driver ICs (the backlight is not included in this OLB module).

The 8.0" screen produces 800(*3)X480 resolution image. By applying R.G.B. input signal, full color images are displayed.

General specifications are summarized in the following table:

ITEM	SPECIFICATION
Display Area (mm)	176.64(W) x 99.36(H)
Number of Pixels	800(H) x 3 (RGB) x 480(V)
Pixel Pitch (mm)	0.2208(W) x 0.2070(H)
Color Pixel Arrangement	RGB vertical stripes
Display Mode	Normally white
Number of color	16.2M
Viewing Direction	6:00 o'clock
Response Time (Tr+Tf)	25ms(typ.)
Panel Transmittance (%)	5.8(typ)
NTSC	50%(typ.)
Power Consumption(W)	387mW (typ.)
Surface Treatment	Anti-Glare 3H



2. ABSOLUTE MAXIMUM RATINGS

Item	Symbol	Min.	Max.	Unit	Note
Digital Supply Voltage	DVDD	-0.3	+3.96	V	
Analog Supply Voltage	AVDD	-0.5	+14.8	V	
Gate On Voltage	VDDG	-0.3	+40	V	
Gate Off Voltage	VEEG	-20	+0.3	V	
Gate On-Gate Off Voltage	VDDG-VEEG	-0.3	40	V	
Operation Temperature	T _{op}	-20	70	°C	1
Storage Temperature	T _{stg}	-30	80	°C	1

Note1: If users use the product out off the environmental operation range (temperature and humidity), it will have visual quality concerns.

晶華微 Only Confidential



3. ELECTRICAL CHARACTERISTICS

3.1 Typical operation conditions

Ta=25°C

Item	Symbol	Min.	Typ.	Max.	Unit.	Note.
Digital Supply Voltage	DVDD	3	3.3	3.6	V	
Analog Supply Voltage	AVDD	9.0	9.2	9.4	V	
Gate On Voltage	VODG	17	18	19	V	
Gate Off Voltage	VEEG	-6.6	-6	-5.4	V	
Common Voltage	VCOM	3.8	4.0	4.2	V	Note1
Logic Input Voltage	V _{IH}	0.7DVDD	-	DVDD	V	
	V _{IL}	GND	-	0.3DVDD	V	
Gamma Voltage	V1		9.01		V	
	V2		7.22		V	
	V3		6.88		V	
	V4		6.57		V	
	V5		5.525		V	
	V6		3.925		V	
	V7		2.854		V	
	V8		2.484		V	
	V9		2.04		V	
	V10		0.21		V	

[Note1] Please adjust VCOM to make the flicker level be minimum.



3.2 TFT-LCD Current consumption

Item	Symbol	Condition	Min.	Typ.	Max.	Unit.	Note.
Gate on Current	I _{VDDG}	V _{DG} = 18 V	-	0.5	1	mA	Note1
Gate off Current	I _{VEEG}	V _{EEG} = -6 V	-	0.5	1	mA	Note1
Digital Current	I _{DVDD}	V _{DVDD} = 3.3V	-	10	15	mA	Note1
Analog Current	I _{AVDD}	V _{AVDD} = (9.6) V	-	30	35	mA	Note1
Total Power Consumption	PC		-	321	396	mW	Note1

Note1: Typical: Under Gray-level pattern
Maximum: Under black pattern

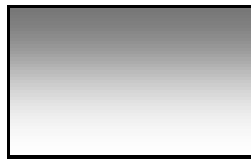

Gray-level Pattern

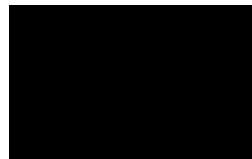

Black Pattern

3.3 Power - Signal sequence

Power On : DVDD→AVDD/VEEG→VDDG→Video & Logic Signal→Backlight
Power Off : Backlight→ Video & Logic Signal→VDDG→AVDD/VEEG→DVDD

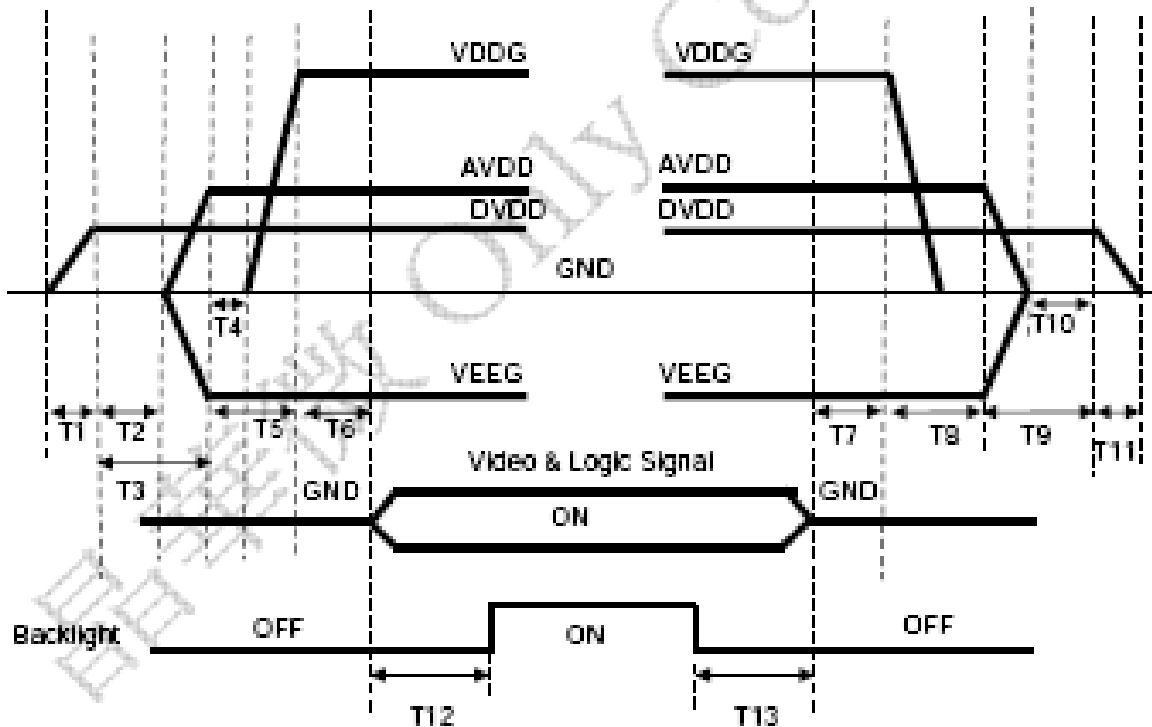

$0 < T1 \leq 10\text{ms}$
 $T2 > 0\text{ms}$
 $T3 > 20\text{ms}$
 $T4 > 0\text{ms}$
 $T5 > 10\text{ms}$
 $0 < T6 \leq 10\text{ms}$
 $T12 \geq 200\text{ms}$

$T7 > 0\text{ms}$
 $T8 > 0\text{ms}$
 $T9 > 0\text{ms}$
 $T10 > 0\text{ms}$
 $0 < T11 \leq 10\text{ms}$
 $T13 \geq 200\text{ms}$



3.4 Timing characteristics of input signals

	ITEM	SYMBOL	MIN.	TYP.	MAX.	UNIT	Note
DCLK	Dot Clock	f_{DCLK}	26	30	35	MHz	
	DCLK pulse duty	T_{cwh}	40	50	60	%	
DE	Setup Time	T_{esu}	8	-	-	ns	
	Hold time	T_{ehd}	8	-	-	ns	
	Horizontal Period	t_H	908	928	1000	t_{CLK}	
	Horizontal Valid	t_{HA}	800				
	Horizontal Blank	t_{HB}	108	128	200	t_{CLK}	
	Vertical Period	t_V	517	525	700	t_{CLK}	
	Vertical Valid	t_{VA}	480				
	Vertical Blank	t_{VB}	37	45	220	t_{CLK}	
	SYNC	HSYNC Setup Time	T_{hst}	8	-	-	ns
HSYNC Hold Time		T_{hhd}	8	-	-	ns	
VSYNC Setup Time		T_{vst}	8	-	-	ns	
VSYNC Hold Time		T_{vhhd}	8	-	-	ns	
Horizontal Period		t_H	908	928	1000	t_{CLK}	
Horizontal Pulse Width		t_{HPW}	48			t_{CLK}	
Horizontal Back Porch		t_{HB}	40			t_{CLK}	
Horizontal Front Porch		t_{HFP}	20	40	112	t_{CLK}	
Horizontal Valid		t_{HD}	800				
Vertical Period		t_V	517	525	700	t_H	
Vertical Pulse Width		t_{VPW}	3			t_H	
Vertical Back Porch		t_{VB}	29			t_H	
Vertical Front Porch		t_{VFP}	5	13	188	t_H	
Vertical Valid	t_{VD}	480					
Frame	Frame Rate	--	55	60	-	Hz	-
DATA	Setup Time	T_{dsu}	8	-	-	ns	
	Hold Time	T_{dhd}	8	-	-	ns	

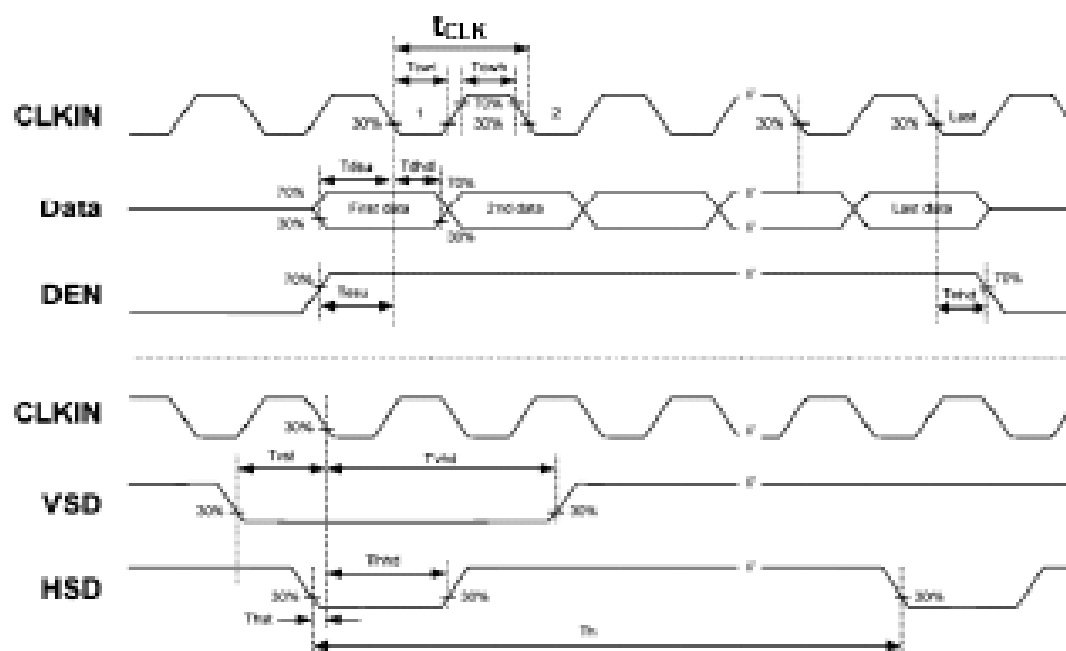



CPT

CHUNGHWA PICTURE TUBES, LTD.,

DE mode

Horizontal timing :

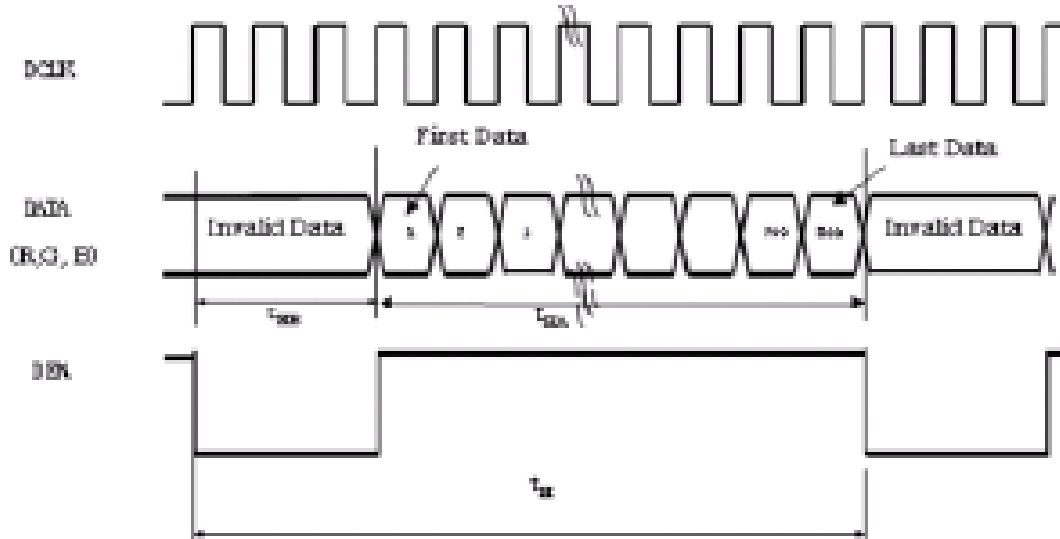

Vertical timing :

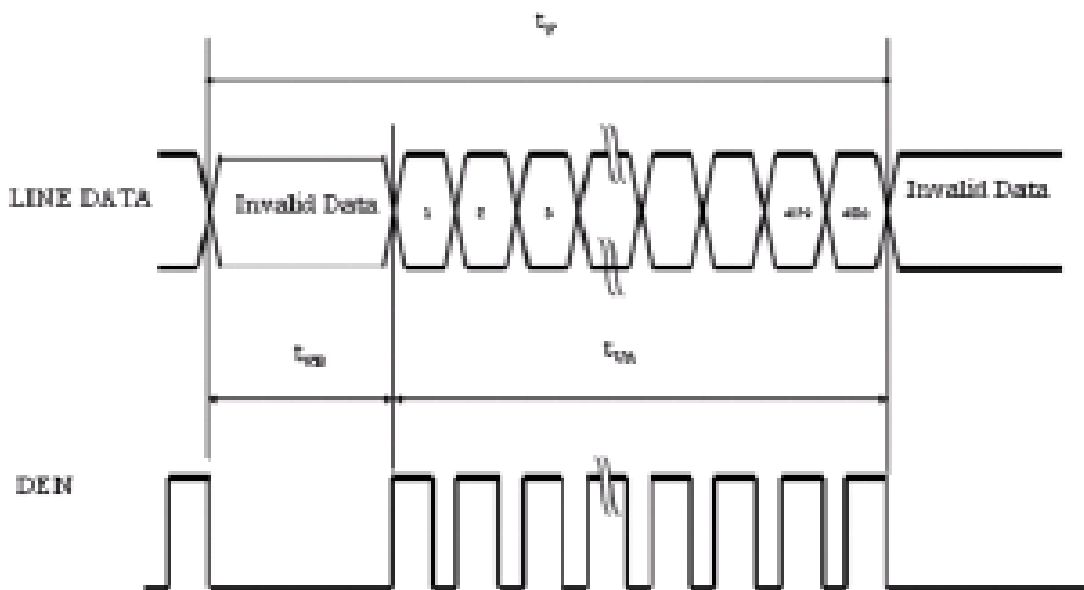



CPT

CHUNGHWA PICTURE TUBES, LTD.,

SYNC mode

Horizontal timing :

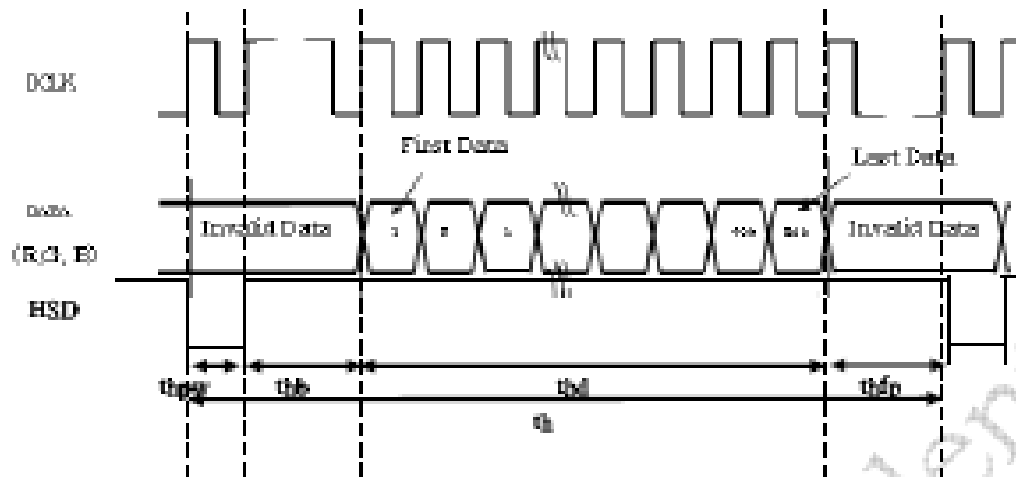

Vertical timing :

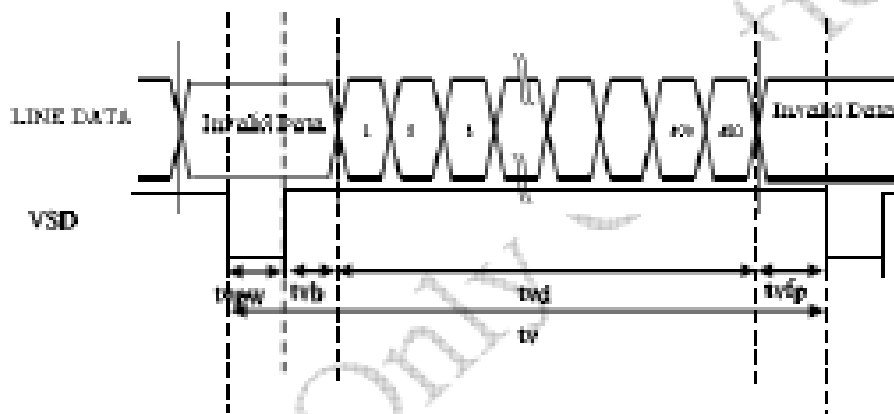



4. INTERFACE CONNECTION:

4.1 CN1(Signal of interface)

Pin NO.	SYMBOL	DESCRIPTION
1	AGND	Analog Ground
2	AVDD	Analog Power
3	DVDD	Digital Power
4	R0	Data Input(LSB)
5	R1	Data Input
6	R2	Data Input
7	R3	Data Input
8	R4	Data Input
9	R5	Data Input
10	R6	Data Input
11	R7	Data Input(MSB)
12	G0	Data Input(LSB)
13	G1	Data Input
14	G2	Data Input
15	G3	Data Input
16	G4	Data Input
17	G5	Data Input
18	G6	Data Input
19	G7	Data Input(MSB)
20	B0	Data Input(LSB)
21	B1	Data Input
22	B2	Data Input
23	B3	Data Input
24	B4	Data Input
25	B5	Data Input
26	B6	Data Input
27	B7	Data Input(MSB)
28	DCLK	Clock input
29	DE	Data Enable signal
30	HSD	Horizontal sync input. Negative polarity
31	VSD	Vertical sync input. Negative polarity
32	MODE	DE/SYNC mode select. Normally pull high H: DE mode. L: HSD/VSD mode
33	RSTB	Global reset pin. Active low to enter reset state. Suggest to connecting with an RC reset circuit for stability. Normally pull high. (R=47KΩ - C=1μF)
34	STBYB	Standby mode, normally pull high STBYB="1", normal operation STBYB="0", timing control, source driver will turn off, all output are high-Z
35	SHLR	Left or Right Display Control
36	DVDD	Digital Power
37	UPDN	Up / Down Display Control
38	GND	Digital Ground
39	AGND	Analog Ground
40	AVDD	Analog Power
41	VCOM	Common Voltage
42	DITH	Dithering setting DITH="H" 8bit resolution(last 2 bit of input data truncated) (default setting) DITH="L" 8bit resolution
43	NC	Not connect
44	NC	Not connect
45	V70	Gamma correction voltage reference
46	V9	Gamma correction voltage reference
47	V8	Gamma correction voltage reference
48	V7	Gamma correction voltage reference
49	V6	Gamma correction voltage reference



CPT

CHUNGHWA PICTURE TUBES, LTD.,

50	V5	Gamma correction voltage reference
51	V4	Gamma correction voltage reference
52	V3	Gamma correction voltage reference
53	V2	Gamma correction voltage reference
54	V1	Gamma correction voltage reference
55	NC	Not connect
56	VDDG	Positive Power for TFT
57	DVDD	Digital Power
58	VEEG	Negative Power for TFT
59	GND	Digital Ground
60	NC	Not connect

[Note] SHLR : left or right setting
UPDN : up or down setting

SHLR	UPDN	Data shifting
DVDD	GND	Left→Right · Up→Down(default)
GND	GND	Right→Left · Up→Down
DVDD	DVDD	Left→Right · Down→Up
GND	DVDD	Right→Left · Down→Up

Definition of scanning direction.

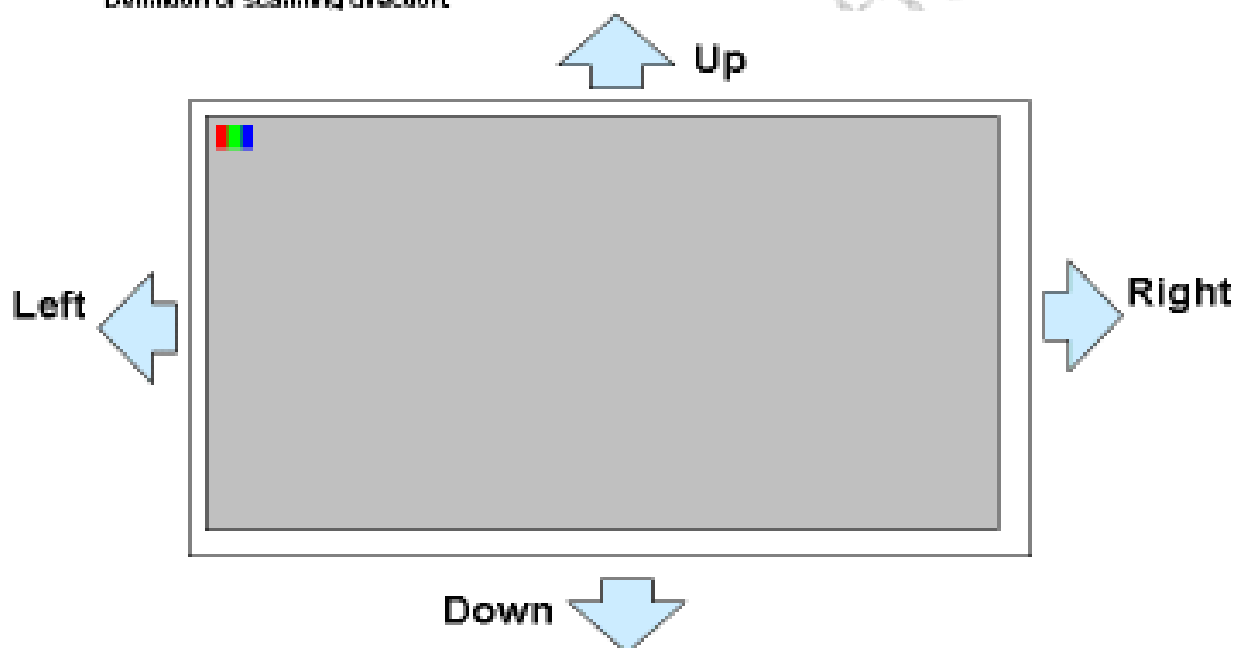



CPT

CHUNGHWA PICTURE TUBES, LTD.

5. MECHANICAL DIMENSION

5.1 Front Side

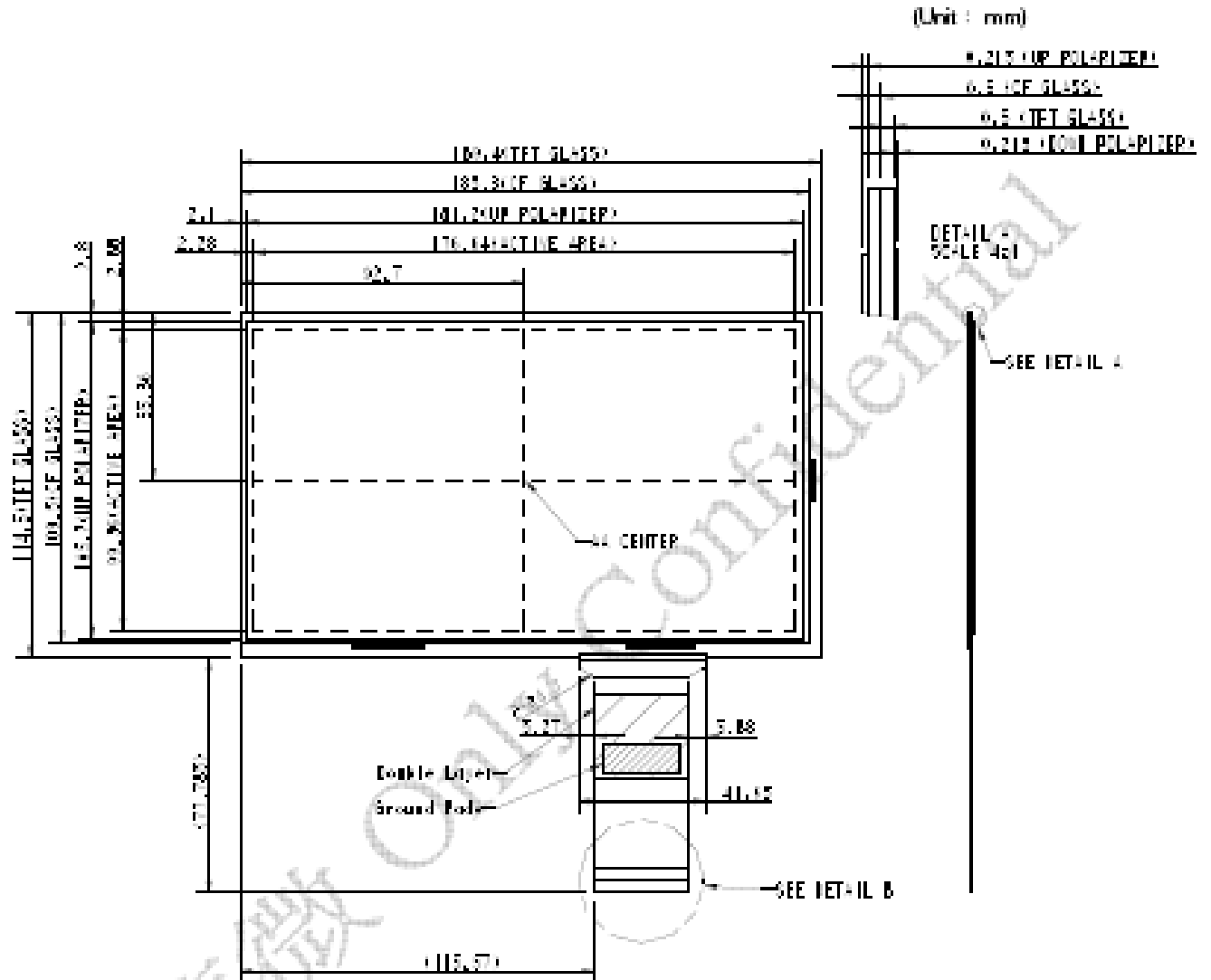



5.2 Rear Side

(Unit: mm)

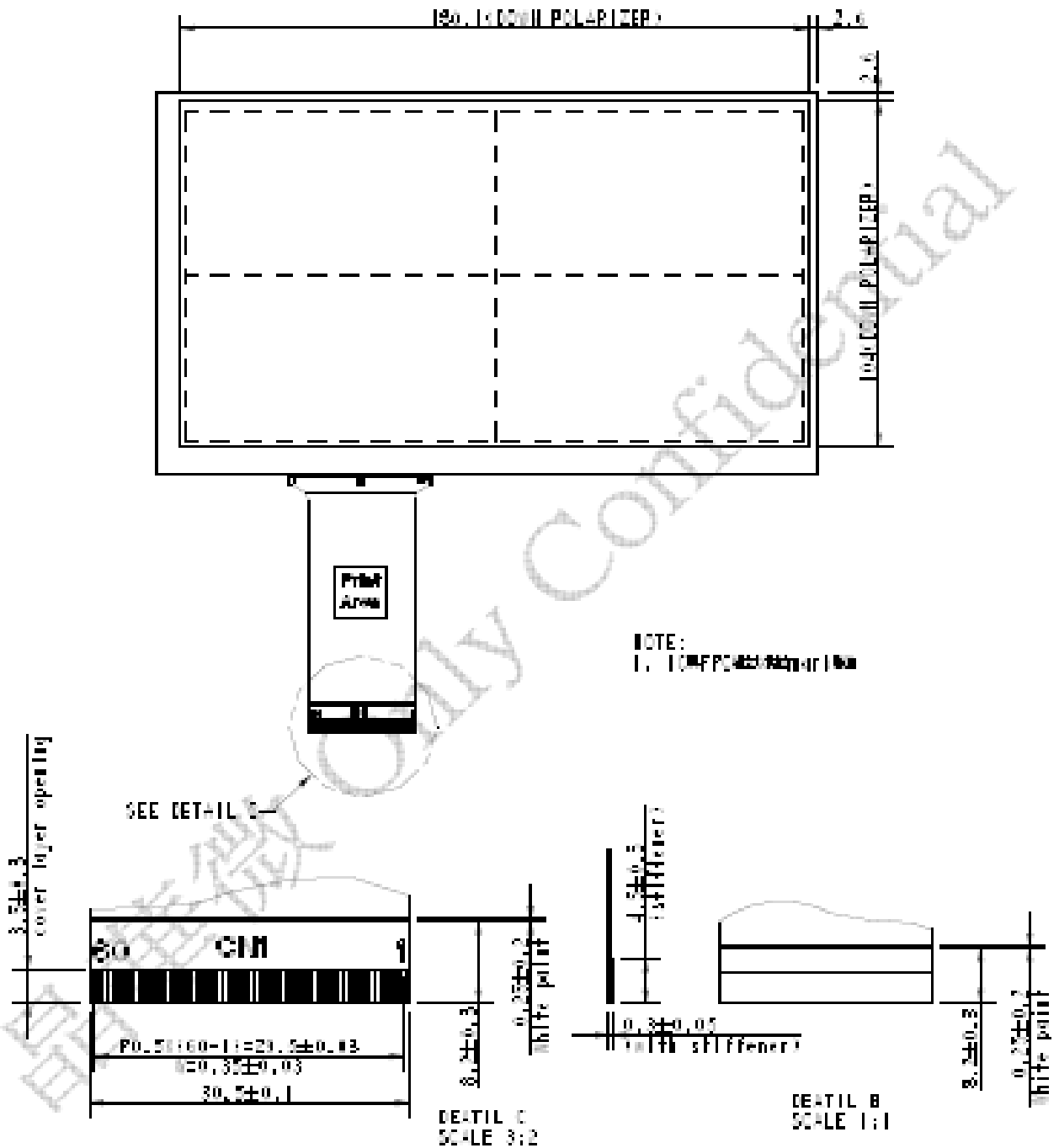

NOTE: General tolerance = ±0.3mm



6. OPTICAL CHARACTERISTICS

(Use CPT LED backlight)

Ta=25℃

ITEM	SYMBOL	CONDITION	MIN.	TYP.	MAX.	UNIT	NOTE	
Panel Transmittance	T	~	5.2	5.8	--	%		
Response Time	Tr + Tf	Point-5	--	25	35	ms	1	
Viewing Angle	Left	Deg.	Point-5 CR ≥ 10	65	75	--	°	2
	Right	Deg.		65	75	--		2
	Upper	Deg.		40	50	--	°	2
	Lower	Deg.		70	80	--		2
Color Filter Chromaticity	White	x	$\theta - \phi - 0^\circ$	0.260	0.310	0.360		3
		y		0.280	0.330	0.380		3
	Red	x	$\theta - \phi - 0^\circ$	(0.547)	(0.597)	(0.647)		3
		y		(0.298)	(0.348)	(0.398)		3
	Green	x	$\theta - \phi - 0^\circ$	(0.303)	(0.353)	(0.403)		3
		y		(0.541)	(0.591)	(0.641)		3
	Blue	x	$\theta - \phi - 0^\circ$	(0.110)	(0.160)	(0.210)		3
		y		(0.098)	(0.148)	(0.198)		3

Note 1: Definition of Response Time.(White-Black)

The response time is defined as the time interval between the 10% and 90% amplitudes.

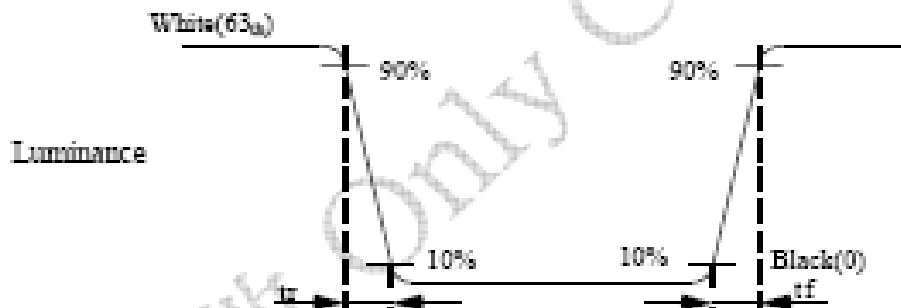

Fig. 6-1 Measuring point

Note 2: Definition of Viewing Angle(θ, ω)

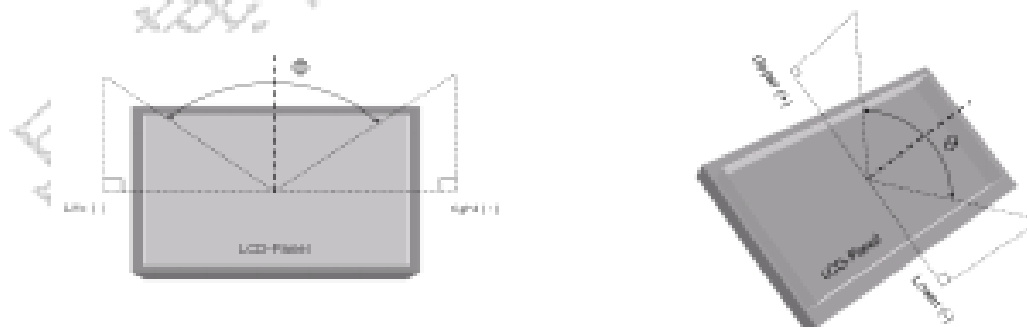

Fig.6-2 Definition of Viewing Angle

Note 3: Use CPT LED Backlight



7. RELIABILITY TEST

(These tests are conducted with CPT backlight.)

7.1 Temperature and Humidity

TEST ITEMS	CONDITIONS	NOTE
High Temperature Operation	70°C ; 240hrs	
High Temperature Storage	80°C ; 240hrs	
High Temperature High Humidity Operation	60°C ; 90%RH ; 240hrs	
Low Temperature Operation	-20°C ; 240hrs	
Low Temperature Storage	-30°C ; 240hrs	
Thermal Shock	-30°C (0.5hr) ~ 80°C (0.5hr) ; 200 Cycles	Non-Operating
Image Sticking	25°C ; 4hrs	Note 1

Note :

Condition of Image Sticking test : 25 °C ± 2 °C

Operation with test pattern sustained for 24 hrs, then change to gray pattern immediately.

After 5 mins, the mura must be disappeared completely

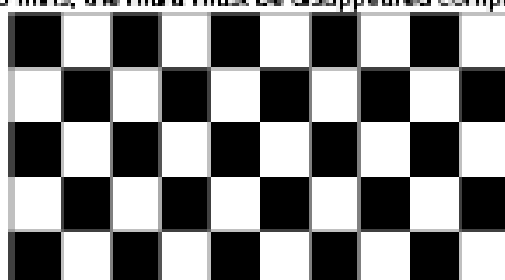

(a) Image sticking pattern



(b) mid-gray pattern

7.2 Shock and Vibration

TEST ITEMS	CONDITIONS
Shock (Non-operation)	<ul style="list-style-type: none"> Shock level: 980m/s²(equal to 100G). Waveform: half sinusoidal wave, 6ms. Number of shocks: one shock input in each direction of three mutually perpendicular axes for a total of three shock inputs.
Vibration (Non-operation)	<ul style="list-style-type: none"> 1. Random: <ul style="list-style-type: none"> 1.04 Grms, 5-500Hz, X/Y/Z, 30min/each direction 2. Sine: <ul style="list-style-type: none"> Freq. Range: 8-33.3Hz Stroke: 1.3mm Sweep: 2.9G, 33.3-400Hz X/Z: 2hr, Y: 4hr, cyc: 15min

7.3 Electrostatic Discharge

TEST ITEM	CONDITIONS	NOTE
ESD	150pF · 330Ω · ±8kV±15kV air& contact test	1
	200pF · 0Ω · ±200V contact test	2

Note: Measure point :

1. LCD glass and metal bezel
2. IF connector pins



7.4 Judgment Standard

The judgment of the above test should be made as follow:

Pass: Normal display image with no obvious non-uniformity and no line defect.

Partial transformation of the module parts should be ignored.

Fail: No display image, obvious non-uniformity, or line defects.

8. WARRANTY

8.1 The period is within 12 months since the date of shipping out under normal using and storage conditions.

Suggesting Storage Condition

Storage temperature range: 20 – 26℃

Storage humidity range: 47 – 59 RH%

8.2 The warranty will be avoided in case of defect induced by customer

8.3 The warranty start date will be the shipping date from CPT.

8.4 The warranty will be void in case of defect induced by customer.

8.5 The warranty does not apply under the following circumstances:

- (a)The visual defects ,such as dent, crack, scratch, are induced by customer.
- (b)The glass broken which is induced by customer.
- (c)The defects are found out of warranty period