



Document Title	HSD090IFW1-A Preliminary Specification	Page No.	1/24
Document No.	DC140-000***	Revision	1.0

TO :

Date : Sep., 18, 2015

HannStar Product Specification (Preliminary)

9” Color TFT-LCD Module

Model: **HSD090IFW1-A ****

- Note: 1.Please contact HannStar Display Corp. before designing your product based on this module specification.
2.The information contained herein is presented merely to indicate the characteristics and performance of our products. No responsibility is assumed by HannStar for any intellectual property claims or other problems that may result from application based on the module described herein.
3.The mark “ ** ” of Model means sub-model code.



Document Title	HSD090IFW1-A Preliminary Specification	Page No.	2/24
Document No.	DC140-000***	Revision	1.0

Record of Revisions

Rev.	Date	Sub-Model	Description of change
1.0	Sep., 18, 2015	A**	Preliminary Product Specification was first released



Document Title	HSD090IFW1-A Preliminary Specification	Page No.	3/24
Document No.	DC140-000***	Revision	1.0

Contents

1.0	General description	p.4
2.0	Absolute maximum ratings.....	p.5
3.0	Optical characteristics.....	p.6
4.0	Block diagram	p.10
5.0	Interface pin connection	p.12
6.0	Electrical characteristics	p.14
7.0	Reliability test items	p.18
8.0	Outline dimension	p.19
9.0	Lot mark	p.20
10.0	Package specification	p.21
11.0	General precaution	p.22

Document Title	HSD090IFW1-A Preliminary Specification	Page No.	4/24
Document No.	DC140-000***	Revision	1.0

1.0 GENERAL DESCRIPTION

1.1 Introduction

HannStar Display model HSD090IFW1-A is a color active matrix thin film transistor (TFT) liquid crystal display (LCD) that uses amorphous silicon TFT as a switching device. This model is composed of a TFT LCD panel, a driving circuit and a back light system. This TFT LCD has a 9" (16:9) inch diagonally measured active display area with WSVGA (1024 horizontal by 600 vertical pixel) resolution.

1.2 Features

- 9 (16:9 diagonal) inch configuration
- 16.2M color by 6 bit + FRC
- ROHS / Halogen Free Compliance

1.3 Applications

- Automobile

1.4 General information

Item	Specification	Unit	
Outline Dimension	211.1(H) x 126.5(V) x5.7(Typ.)	mm	
Display area	196.608(H) x 114.15(V)	mm	
Number of Pixel	1024 RGB (H) x 600(V)	pixels	
Pixel pitch	0.192(H) x 0.19025(V)	mm	
Pixel arrangement	RGB Vertical stripe		
Display mode	Normally Black		
Surface treatment	Antiglare, Hard-Coating (3H)		
Weight	240 (Typ.)	g	
Back-light	Single LED (Side-Light type)		
Power Consumption	Logic System	0.3(Max)	W
	B/L System	2.769 (Max.)	W

1.5 Mechanical Information

Item	Min.	Typ.	Max.	Unit	
Module Size	Horizontal (H)	210.8	211.1	211.4	mm
	Vertical (V)	126.2	126.5	126.8	mm
	Depth (D)	5.4	5.7	6	mm
Weight	—	240	—	g	

Document Title	HSD090IFW1-A Preliminary Specification	Page No.	5/24
Document No.	DC140-000***	Revision	1.0

2.0 ABSOLUTE MAXIMUM RATINGS

2.1 Electrical Absolute Rating

2.1.1 TFT LCD Module

Parameters	Symbol	Min.	Max.	Unit	Note
Power Supply voltage	VDD	-0.3	5	V	
	AVDD	-0.5	15	V	
	VGH	-0.3	42	V	
	VGL	-20	0.3	V	
	VGH-VGL	-0.3	40	V	

2.2 Environment Absolute Rating

Item	Symbol	Min.	Max.	Unit	Note
Operating Temperature	T _{opa}	-30	85	°C	
Storage Temperature	T _{stg}	-30	85	°C	

Document Title	HSD090IFW1-A Preliminary Specification	Page No.	6/24
Document No.	DC140-000***	Revision	1.0

3.0 OPTICAL CHARACTERISTICS

3.1 Optical specification

Item		Symbol	Condition	Min.	Typ.	Max.	Unit	Note
Contrast		CR	$\theta=0$	640	800	—		(1)(2)
Response time	Rising	T_R		—	18		msec	(1)(3)
	Falling	T_F		—	17			
White luminance (Center)		Y_L	$\theta=0$ Normal viewing angle	400	500	—	cd/m ²	(1)(4) ($I_L=140mA$)
Color chromaticity (CIE1931)	White	W_x		0.270	0.310	0.350		(1)(4)
		W_y		0.290	0.330	0.370		
	Red	R_x			TBD			
		R_y			TBD			
	Green	G_x			TBD			
		G_y			TBD			
	Blue	B_x			TBD			
		B_y			TBD			
Viewing angle	Hor.	θ_L		CR>10	—	85	—	
		θ_R	—		85	—		
	Ver.	θ_U	—		85	—		
		θ_D	—		85	—		
Brightness uniformity		B_{UNI}	$\theta=0$	—	70	—	%	(5)
Optima View Direction		Free						(6)

3.2 Measuring Condition

- Measuring surrounding : dark room
- LED current I_L : 140mA
- Ambient temperature : 25±2°C
- 15min. warm-up time.

Document Title	HSD090IFW1-A Preliminary Specification	Page No.	7/24
Document No.	DC140-000***	Revision	1.0

3.3 Measuring Equipment

- FPM520 of Westar Display technologies, INC., which utilized SR-3 for Chromaticity and BM-5A for other optical characteristics.
- Measuring spot size : 20 ~ 21 mm

Note (1) Definition of Viewing Angle:

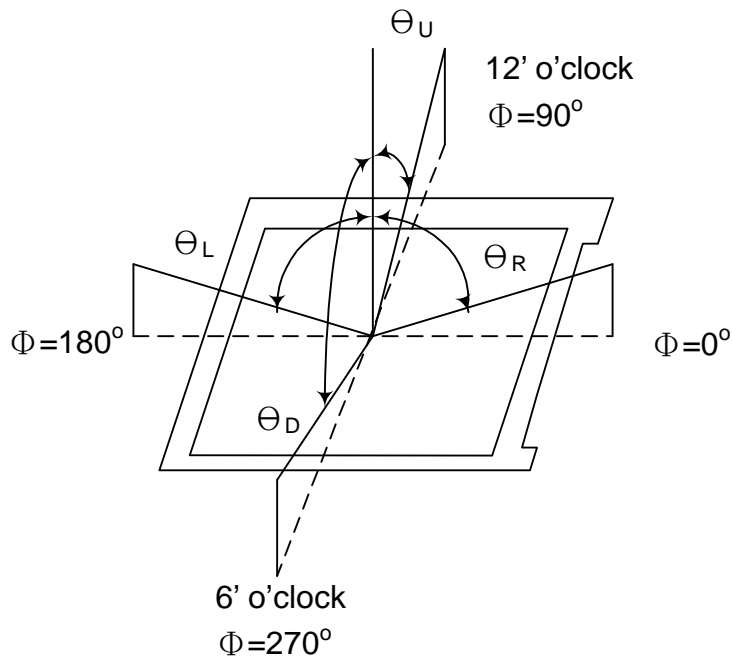

Note (2) Definition of Contrast Ratio (CR) :
measured at the center point of panel

$$CR = \frac{\text{Luminance with all pixels white}}{\text{Luminance with all pixels black}}$$

Document Title	HSD090IFW1-A Preliminary Specification	Page No.	8/24
Document No.	DC140-000***	Revision	1.0

Note (3) Definition of Response Time : Sum of T_R and T_F

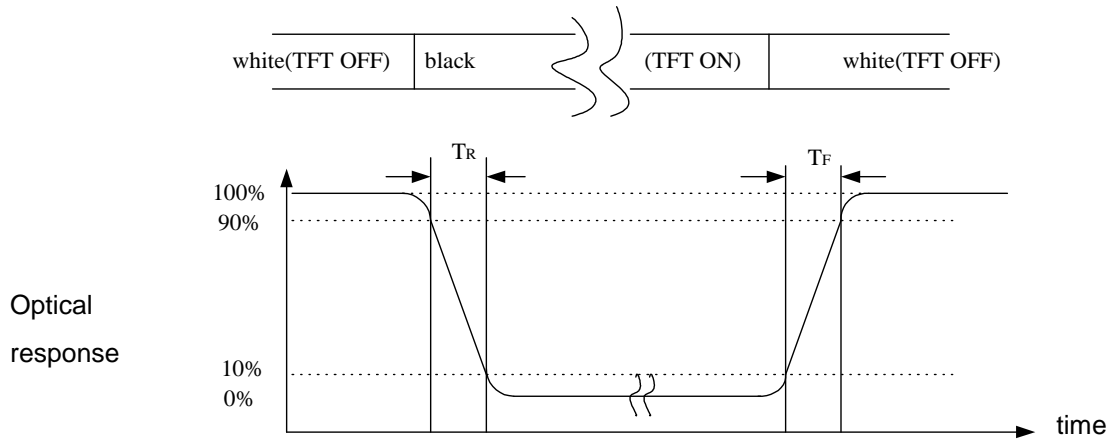

Note (4) Definition of optical measurement setup

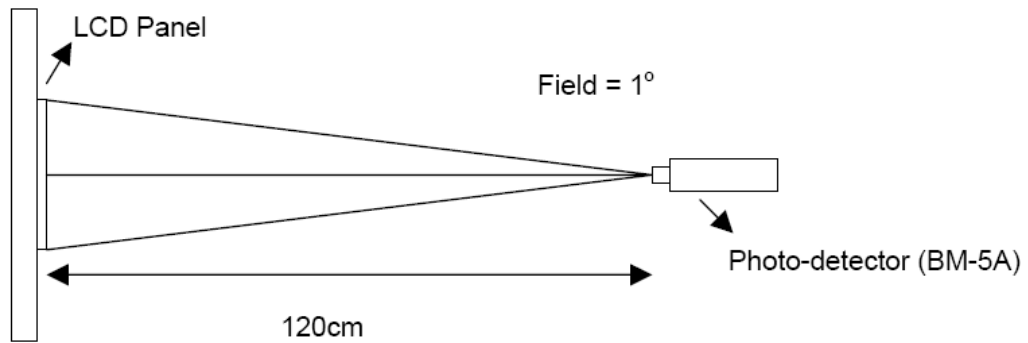

Document Title	HSD090IFW1-A Preliminary Specification	Page No.	9/24
Document No.	DC140-000***	Revision	1.0

Note (5) Definition of brightness uniformity

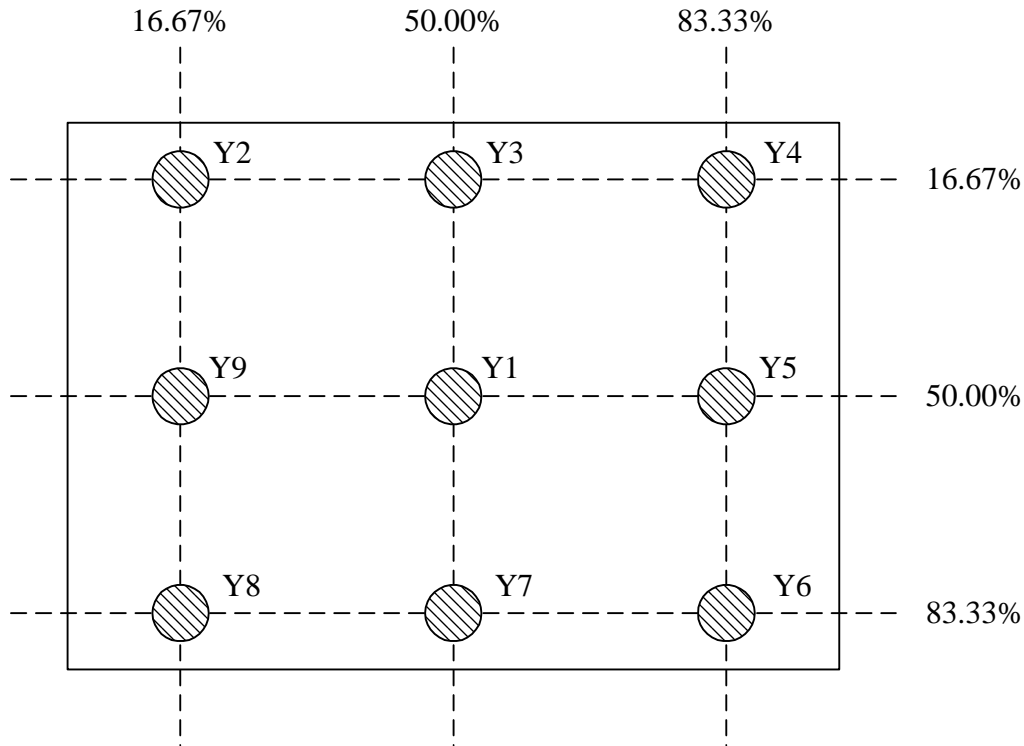

$$\text{Luminance uniformity} = \frac{(\text{Min Luminance of 9 points})}{(\text{Max Luminance of 9 points})} \times 100\%$$

Note (6) : Rubbing Direction (The different Rubbing Direction will cause the different optima view direction.)

Document Title	HSD090IFW1-A Preliminary Specification	Page No.	10/24
Document No.	DC140-000***	Revision	1.0

4.0 BLOCK DIAGRAM

4.1 TFT LCD Module:

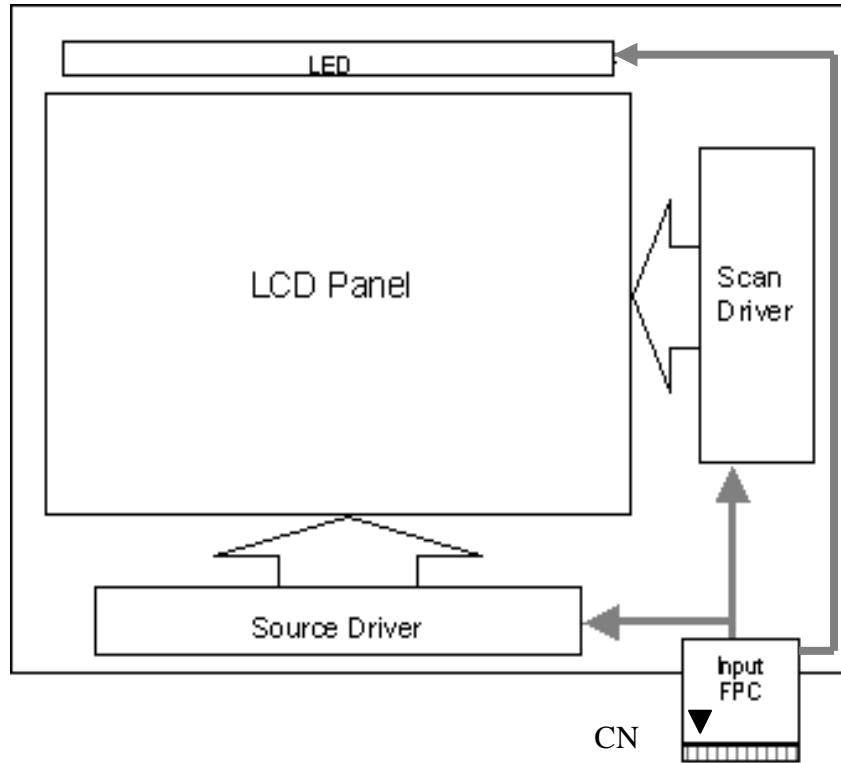

4.2 Pixel Format

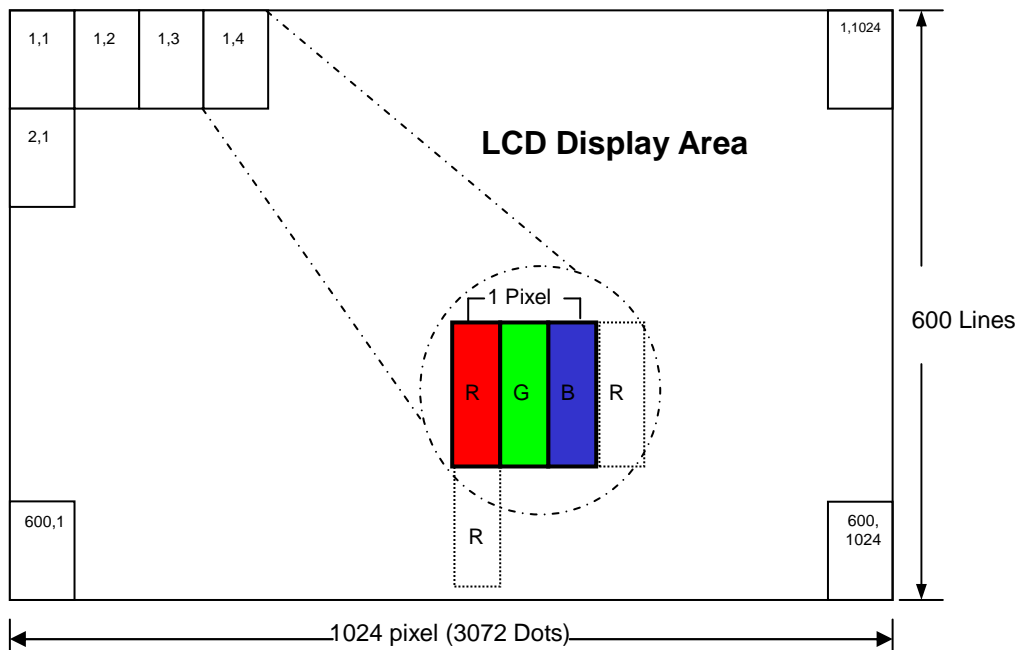

Document Title	HSD090IFW1-A Preliminary Specification	Page No.	11/24
Document No.	DC140-000***	Revision	1.0

4.3 Relationship Between Displayed Color and Input

	Display	MSB				LSB				MSB				LSB				MSB				LSB				Gray scale Level			
		R7	R6	R5	R4	R3	R2	R1	R0	G7	G6	G5	G4	G3	G2	G1	G0	B7	B6	B5	B4	B3	B2	B1	B0				
Basic color	Black	L	L	L	L	L	L	L	L	L	L	L	L	L	L	L	L	L	L	L	L	L	L	L	L	L	L	L	-
	Blue	L	L	L	L	L	L	L	L	L	L	L	L	L	L	L	L	H	H	H	H	H	H	H	H	H	H	H	-
	Green	L	L	L	L	L	L	L	L	L	L	L	L	L	L	L	L	H	H	H	H	H	H	H	H	H	H	H	-
	Light Blue	L	L	L	L	L	L	L	L	L	L	L	L	L	L	L	L	H	H	H	H	H	H	H	H	H	H	H	-
	Red	H	H	H	H	H	H	H	H	H	H	H	H	H	H	H	H	L	L	L	L	L	L	L	L	L	L	L	-
	Purple	H	H	H	H	H	H	H	H	H	H	H	H	H	H	H	H	L	L	L	L	L	L	L	L	L	L	L	-
	Yellow	H	H	H	H	H	H	H	H	H	H	H	H	H	H	H	H	H	H	H	H	H	H	H	H	H	H	H	-
	White	H	H	H	H	H	H	H	H	H	H	H	H	H	H	H	H	H	H	H	H	H	H	H	H	H	H	H	-
Gray scale of Red	Black	L	L	L	L	L	L	L	L	L	L	L	L	L	L	L	L	L	L	L	L	L	L	L	L	L	L	L	L0
	Dark ↑	L	L	L	L	L	L	L	L	L	L	L	L	L	L	L	L	L	L	L	L	L	L	L	L	L	L	L	L1
		L	L	L	L	L	L	L	L	L	L	L	L	L	L	L	L	L	L	L	L	L	L	L	L	L	L	L	L2
		:	:	:	:	:	:	:	:	:	:	:	:	:	:	:	:	:	:	:	:	:	:	:	:	:	:	:	L3...L251
	Light ↓	H	H	H	H	H	H	L	L	L	L	L	L	L	L	L	L	L	L	L	L	L	L	L	L	L	L	L	L252
		H	H	H	H	H	H	L	H	L	L	L	L	L	L	L	L	L	L	L	L	L	L	L	L	L	L	L	L253
		H	H	H	H	H	H	L	H	L	L	L	L	L	L	L	L	L	L	L	L	L	L	L	L	L	L	L	L254
Red	H	H	H	H	H	H	H	H	H	H	H	H	H	H	H	H	L	L	L	L	L	L	L	L	L	L	L	Red L255	
Gray scale of Green	Black	L	L	L	L	L	L	L	L	L	L	L	L	L	L	L	L	L	L	L	L	L	L	L	L	L	L	L	L0
	Dark ↑	L	L	L	L	L	L	L	L	L	L	L	L	L	L	L	L	L	L	L	L	L	L	L	L	L	L	L	L1
		L	L	L	L	L	L	L	L	L	L	L	L	L	L	L	L	L	L	L	L	L	L	L	L	L	L	L	L2
		:	:	:	:	:	:	:	:	:	:	:	:	:	:	:	:	:	:	:	:	:	:	:	:	:	:	:	L3...L251
	Light ↓	L	L	L	L	L	L	L	L	L	L	L	L	L	L	L	L	H	H	H	H	H	L	L	L	L	L	L	L252
		L	L	L	L	L	L	L	L	L	L	L	L	L	L	L	L	H	H	H	H	H	L	H	L	L	L	L	L253
		L	L	L	L	L	L	L	L	L	L	L	L	L	L	L	L	H	H	H	H	H	L	H	L	L	L	L	L254
Green	L	L	L	L	L	L	L	L	L	L	L	L	L	L	L	H	H	H	H	H	H	H	H	H	H	H	H	Green L255	
Gray scale of Blue	Black	L	L	L	L	L	L	L	L	L	L	L	L	L	L	L	L	L	L	L	L	L	L	L	L	L	L	L	L0
	Dark ↑	L	L	L	L	L	L	L	L	L	L	L	L	L	L	L	L	L	L	L	L	L	L	L	L	L	L	L	L1
		L	L	L	L	L	L	L	L	L	L	L	L	L	L	L	L	L	L	L	L	L	L	L	L	L	L	L	L2
		:	:	:	:	:	:	:	:	:	:	:	:	:	:	:	:	:	:	:	:	:	:	:	:	:	:	:	L3...L251
	Light ↓	L	L	L	L	L	L	L	L	L	L	L	L	L	L	L	L	H	H	H	H	H	L	L	L	L	L	L	L252
		L	L	L	L	L	L	L	L	L	L	L	L	L	L	L	L	H	H	H	H	H	L	H	L	L	L	L	L253
		L	L	L	L	L	L	L	L	L	L	L	L	L	L	L	L	H	H	H	H	H	L	H	L	L	L	L	L254
Blue	L	L	L	L	L	L	L	L	L	L	L	L	L	L	L	H	H	H	H	H	H	H	H	H	H	H	H	Blue L255	
Gray scale of White & Black	Black	L	L	L	L	L	L	L	L	L	L	L	L	L	L	L	L	L	L	L	L	L	L	L	L	L	L	L	L0
	Dark ↑	L	L	L	L	L	L	L	L	L	L	L	L	L	L	L	L	L	L	L	L	L	L	L	L	L	L	L	L1
		L	L	L	L	L	L	L	L	L	L	L	L	L	L	L	L	L	L	L	L	L	L	L	L	L	L	L	L2
		:	:	:	:	:	:	:	:	:	:	:	:	:	:	:	:	:	:	:	:	:	:	:	:	:	:	:	L3...L251
	Light ↓	H	H	H	H	H	H	L	L	H	L	L	L	L	L	L	H	H	H	H	H	L	L	L	L	L	L	L	L252
		H	H	H	H	H	H	L	H	L	L	L	L	L	L	L	H	H	H	H	H	L	H	L	L	L	L	L	L253
		H	H	H	H	H	H	L	H	L	L	L	L	L	L	L	H	H	H	H	H	L	H	L	L	L	L	L	L254
White	H	H	H	H	H	H	H	H	H	H	H	H	H	H	H	H	H	H	H	H	H	H	H	H	H	H	H	White L255	

Document Title	HSD090IFW1-A Preliminary Specification	Page No.	12/24
Document No.	DC140-000***	Revision	1.0

5.0 INTERFACE PIN CONNECTION

FPC connector is used for electronics interface. The recommended model is FH12A-40S-0.5SH manufactured by Hirose.

Pin No.	Symbol	I/O	Function	Note
1	VCOM	P	Common Voltage	
2	VDD	P	Power Voltage for digital circuit	
3	VDD	P	Power Voltage for digital circuit	
4	NC	---	No connection	
5	Reset	I	Global reset pin	Note1
6	U/D	I	Vertical inversion	Note2
7	L/R	I	Horizontal inversion	Note2
8	STBYB	I	Standby mode, Normally pulled high STBYB = "1", normal operation STBYB = "0", timing controller, source driver will turn off, all output are High-Z	
9	GND	P	Ground	
10	RXCLKIN-	I	- LVDS differential data input	
11	RXCLKIN+	I	+ LVDS differential data input	
12	GND	P	Ground	
13	RXIN0-	I	- LVDS differential data input	
14	RXIN0+	I	+ LVDS differential data input	
15	GND	P	Ground	
16	RXIN1-	I	- LVDS differential data input	
17	RXIN1+	I	+ LVDS differential data input	
18	GND	P	Ground	
19	RXIN2-	I	- LVDS differential clock input	
20	RXIN2+	I	+ LVDS differential clock input	
21	GND	P	Ground	
22	RXIN3-	I	- LVDS differential data input	
23	RXIN3+	I	+ LVDS differential data input	
24	GND	P	Ground	
25	SELB	I	6bit/8bit mode selection	Note3
26	GND	P	Ground	
27	AVDD	P	Power for Analog Circuit	
28	GND	P	Ground	
29	VGH	P	Gate ON Voltage	
30	NC	---	No connection	
31	NC	---	No connection	
32	VGL	P	Gate off Voltage	
33	GND	P	Ground	
34	NC	---	No connection	



Document Title	HSD090IFW1-A Preliminary Specification	Page No.	13/24
Document No.	DC140-000***	Revision	1.0

Pin No.	Symbol	I/O	Function	Note
35	LED-	P	LED Cathode	
36	LED-	P	LED Cathode	
37	NC	---	No connection	
38	NC	---	No connection	
39	LED+	P	LED Anode	
40	LED+	P	LED Anode	

I: input O: Output P: Power

Note1 : Global reset pin: Active low to enter reset mode. Suggest connecting with an RC reset circuit for stability. Normally pull high. (R=10KΩ, C=0.1μF)

Note: If RC is not added, users must follow the rule, T2 > 50ms on page 18 item 6.5 power on/off sequence.

Note2 : When L/R="0", set right to left scan direction.

When L/R="1", set left to right scan direction.

When U/D="0", set top to bottom scan direction.

When U/D="1", set bottom to top scan direction.

Note3 : If LVDS input data is 6 bits, SELB must be set to High;

If LVDS input data is 8 bits, SELB must be set to Low.

Document Title	HSD090IFW1-A Preliminary Specification	Page No.	14/24
Document No.	DC140-000***	Revision	1.0

6.0 ELECTRICAL CHARACTERISTICS

6.1 TFT LCD Module

Item	Symbol	Min.	Typ.	Max.	Unit	Note
Supply Voltage	VDD	3.0	3.3	3.6	V	
	VGH	22	23	24	V	Note (1)
	VGL	-9	-10	-11	V	Note (2)
	AVDD	12.3	12.6	12.9	V	
	VCOM	4	4.5	5	V	Note (3)
Input signal voltage	V _{IH}	0.7 VDD	-	VDD	V	
	V _{IL}	0	-	0.3 VDD	V	
Current of power supply	I _{DD}	-	(TBD)	-	mA	VDD =3.3V
	I _{ADD}	-	(TBD)	-	mA	AVDD=12.6V
	I _{GH}	-	(TBD)	-	mA	VGH=23V
	I _{GL}	-	(TBD)	-	mA	VGL=-10V
	I _{vcom}	(TBD)	--	--	mA	VCOM=4.5V

6.2 Switching Characteristics for LVDS Receiver

Item	Symbol	Min.	Typ.	Max.	Unit	Conditions
Differential Input High Threshold	V _{th}	—	—	100	mV	V _{CM} =1.2V
Differential Input Low Threshold	V _{tl}	-100	—	—	mV	
Input Current	I _{IN}	-10	—	+10	uA	
Differential input Voltage	V _{ID}	0.1	—	0.6	V	
Common Mode Voltage Offset	V _{CM}	0.7	1.2	1.6	V	

Document Title	HSD090IFW1-A Preliminary Specification	Page No.	15/24
Document No.	DC140-000***	Revision	1.0

6.1 Bit LVDS input

6.1.2 6bit LVDS input

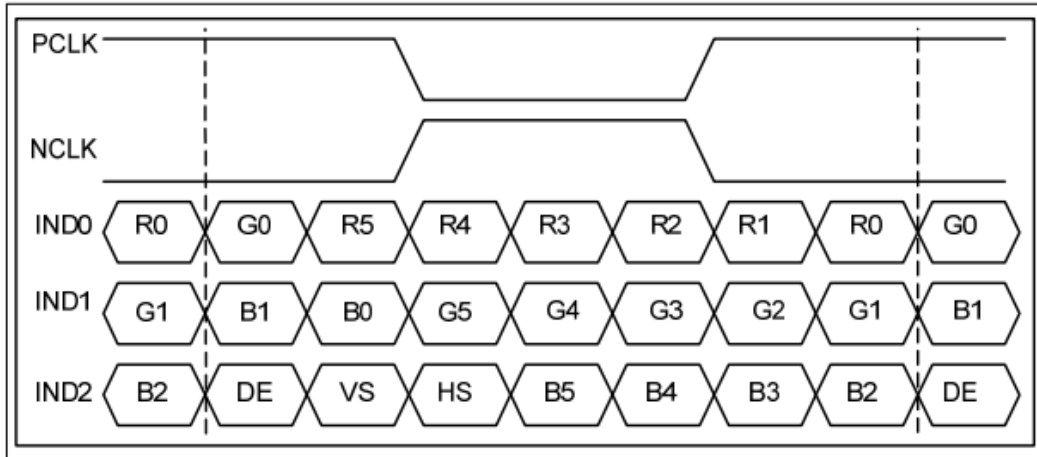

6.1.2 8Bit LVDS input

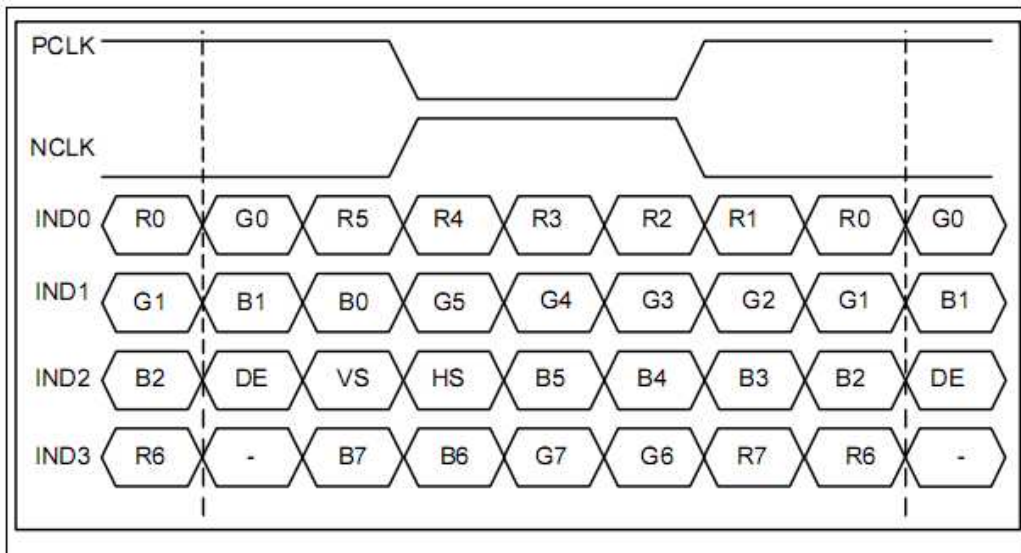

Document Title	HSD090IFW1-A Preliminary Specification	Page No.	16/24
Document No.	DC140-000***	Revision	1.0

6.2 Interface Timing (DE mode)

Parameter	Symbol	Value			Unit
		Min.	Typ.	Max.	
DCLK frequency @Frame rate=60hz	fclk	40.8	51.2	67.2	Mhz
Horizontal display area	thd	1024			DCLK
HSYNC period time	th	1114	1344	1400	DCLK
HSYNC blanking	thb+thfp	90	320	376	DCLK
Vertical display area	tvd	600			H
VSYNC period time	tv	610	635	800	H
VSYNC blanking	tvb+tvfp	10	35	200	H

Timing Diagram of Interface Signal (DE mode)

(1) Vertical input timing

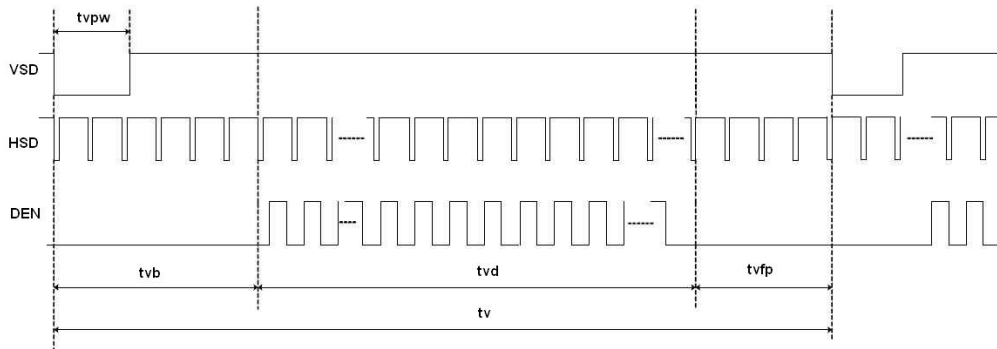

(2) Horizontal Vertical input timing

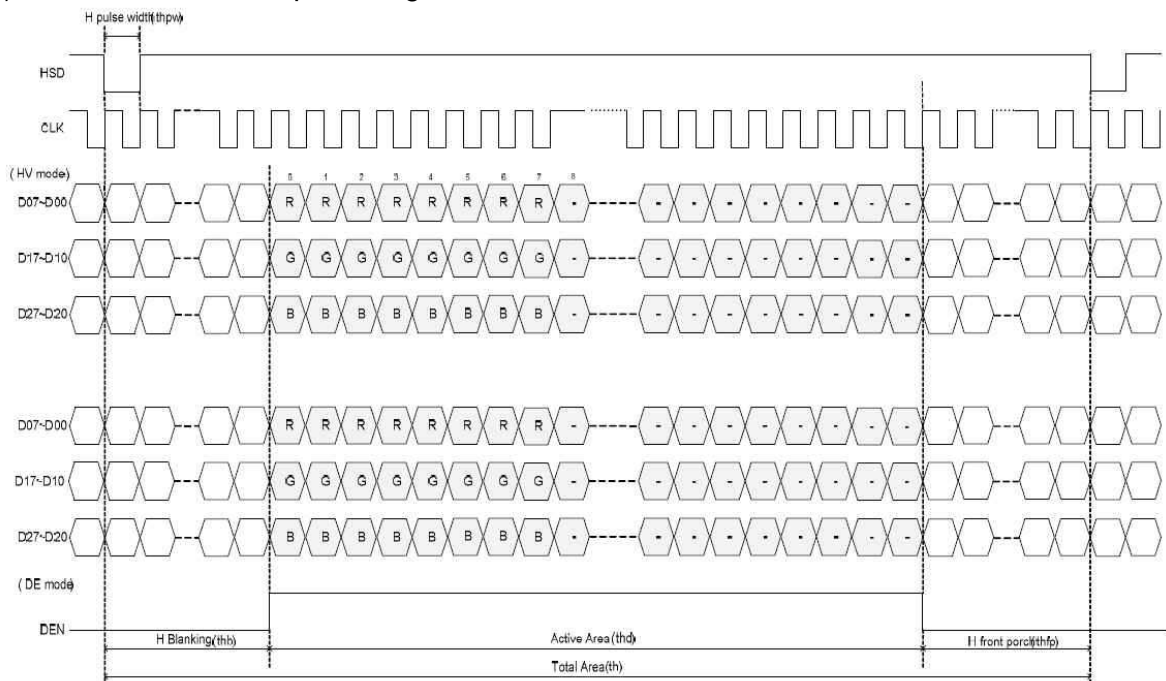

Document Title	HSD090IFW1-A Preliminary Specification	Page No.	17/24
Document No.	DC140-000***	Revision	1.0

6.3 Power On / Off Sequence

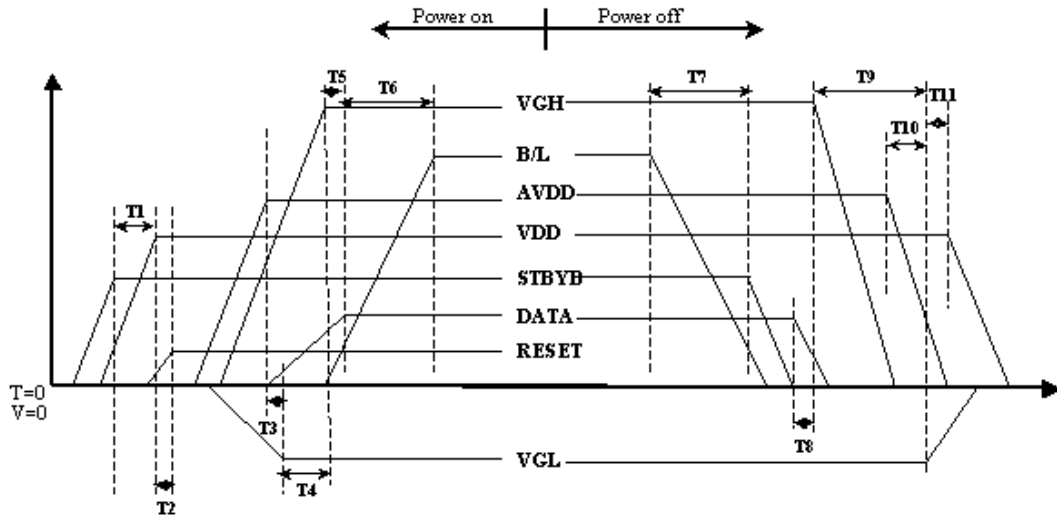

Item	Min.	Typ.	Max.	Unit
T1	0	--	--	ms
T2	50	--	--	ms
T3	5	--	--	ms
T4	10	--	--	ms
T5	20	--	--	ms
T6	50	--	--	ms
T7	20	--	--	ms
T8	10	--	--	ms
T9	20	--	--	ms
T10	10	--	--	ms
T11	20	--	--	ms

Document Title	HSD090IFW1-A Preliminary Specification	Page No.	18/24
Document No.	DC140-000***	Revision	1.0

6.4 Backlight Unit

Parameter	Symbol	Min	Typ	Max	Units	Condition
LED Current	I_F	--	140	--	mA	$T_a=25^\circ\text{C}$
LED Voltage	V_F	--	10.5		Volt	$T_a=25^\circ\text{C}$
LED Life-Time	N/A	30,000	--	--	Hour	$T_a=25^\circ\text{C}$ $I_F=20\text{mA}$ Note (2)

Note (1) LED life time (Hr) can be defined as the time in which it continues to operate under the condition: $T_a=25\pm 3^\circ\text{C}$, typical IL value indicated in the above table until the brightness becomes less than 50%.

Note (2) The "LED life time" is defined as the module brightness decrease to 50% original brightness at $T_a=25^\circ\text{C}$ and $I_L=140\text{mA}$. The LED lifetime could be decreased if operating I_L is larger than 140mA. The constant current driving method is suggested.

Note (3) LED Light Bar Circuit

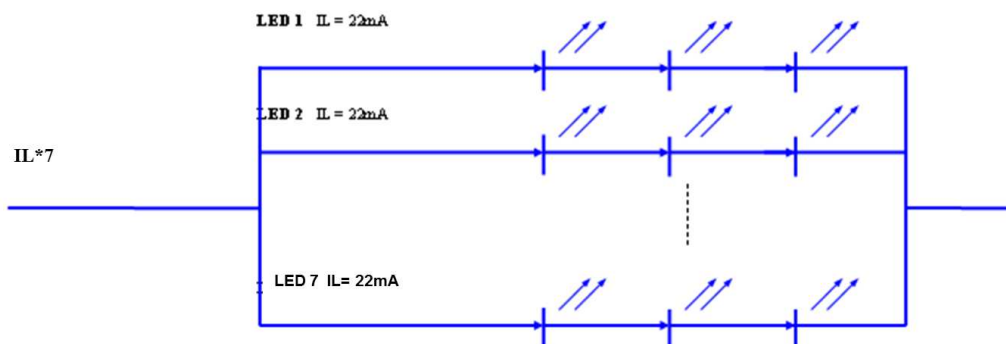

Document Title	HSD090IFW1-A Preliminary Specification	Page No.	19/24
Document No.	DC140-000***	Revision	1.0

7.0 Reliability test items

No.	Item	Conditions	Remark
1	High Temperature Storage	Ta=+85°C, 500hrs	
2	Low Temperature Storage	Ta=-30°C, 500hrs	
3	High Temperature Operation	Ta=+85°C, 500hrs	
4	Low Temperature Operation	Ta=-30°C, 500hrs	
5	High Temperature and High Humidity (operation)	Ta=+65°C, 90%RH, 500hrs	
6	Thermal Cycling Test (non operation)	-30°C(30min) → +85°C(30min), 100 cycles	
7	Electrostatic Discharge	±200V,200pF(0Ω) 1 time/connector	
8	Vibration	1.Random: 1.04G, 10~500Hz, XYZ, 30min/each direction 2.Sine: Freq.1.5G, 8~33.3Hz, Stoke: 1.3mmhz Sweep: 2.9G, 333.3~400 X/Z: 2hrs, Y:4hrs	
9	Shock	Half-Sine, 100G, 6ms, ±XYZ, 1time	
10	Vibration (with carton)	Random: 0.015G ² /Hz, 5~200Hz -6dB/Octave, 200~400Hz XYZ 各方向 2hrs	
11	Drop (with carton)	Drop height condition, basis on the product weight and Follw QB100-0027 1 corner, 3 edges, 6 surfaces	

Note: There is no display function NG issue occurred, all the cosmetic specification is judged before the reliability stress.

Document Title	HSD090IFW1-A Preliminary Specification	Page No.	20/24
Document No.	DC140-000***	Revision	1.0

8.0 OUTLINE DIMENSION

Unit : mm

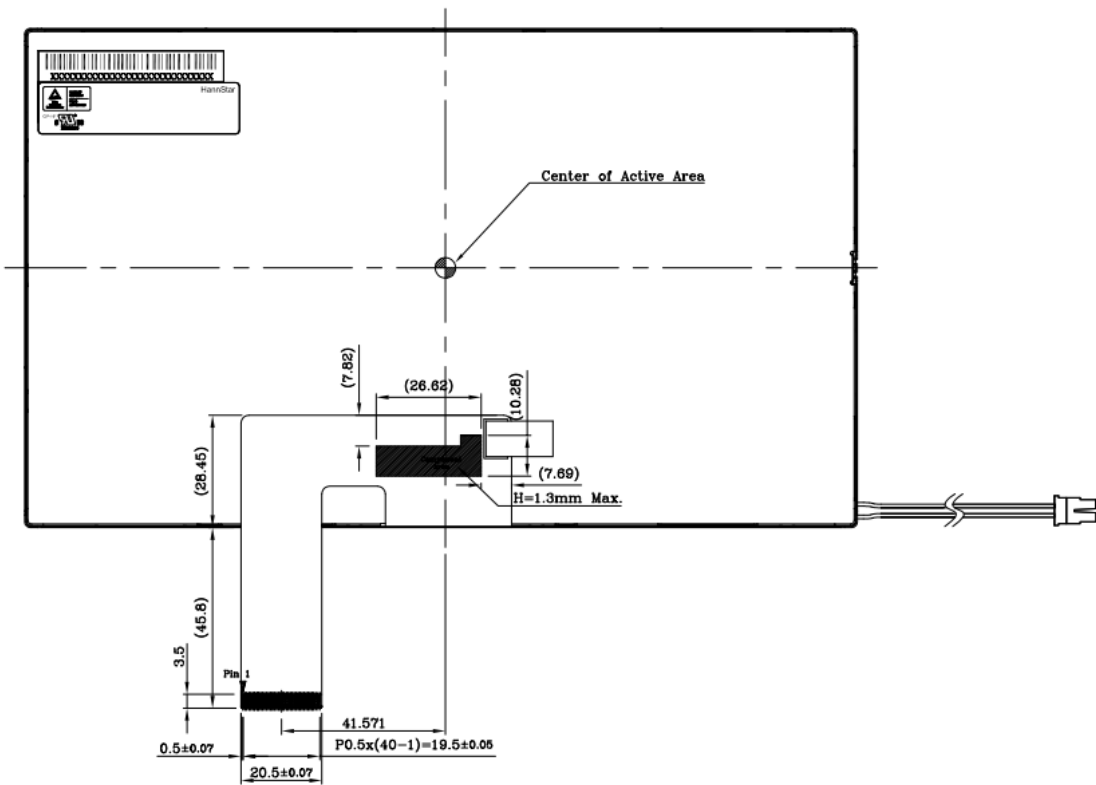
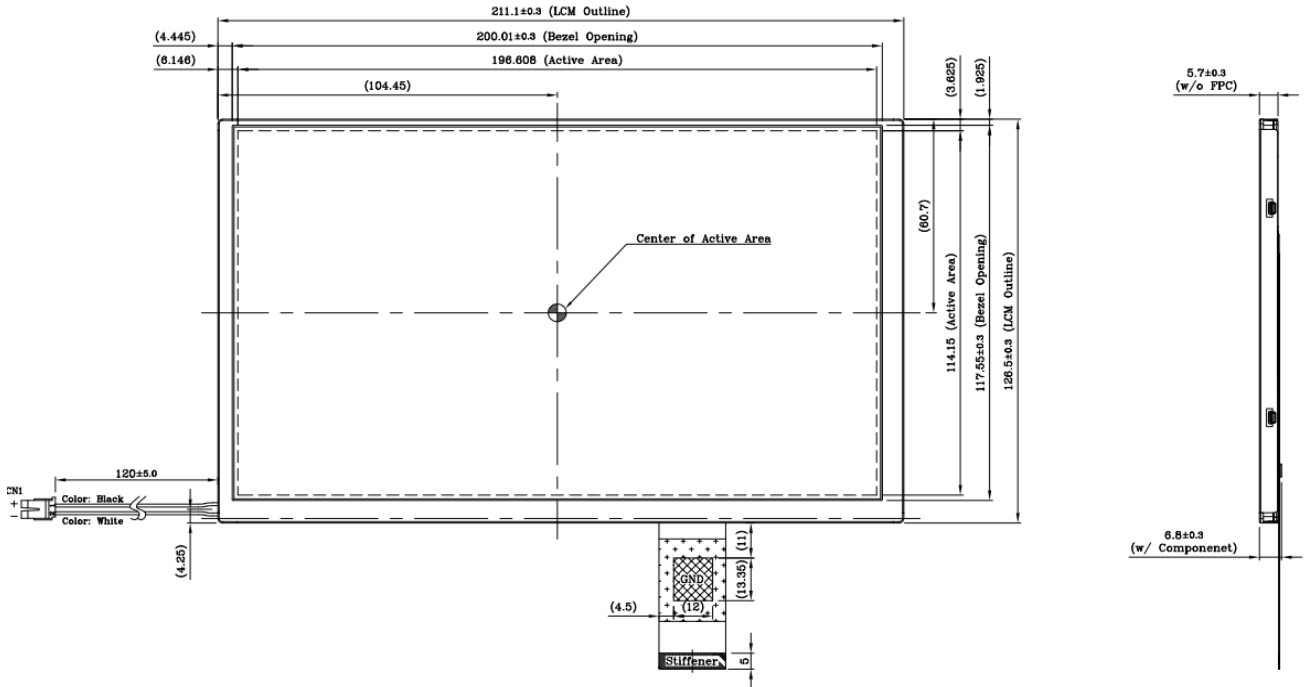

Document Title	HSD090IFW1-A Preliminary Specification	Page No.	21/24
Document No.	DC140-000***	Revision	1.0

9.0 LOT MARK

9.1 Lot Mark

1	2	3	4	5	6	7	8	9	10	11	12	13	14	15
---	---	---	---	---	---	---	---	---	----	----	----	----	----	----

Code 1,2,3,4,5,6: HannStar internal flow control code.

Code 7: production location.

Code 8: production year.

Code 9: production month.

Code 10,11,12,13,14,15: serial number.

Note (1) Production Year: Code 8 is defined by the last number of the year, for example

Year	2006	2007	2008	2009	2010	2011	2012	2013	2014	2015
Mark	6	7	8	9	0	1	2	3	4	5

Note (2) Production Month

Month	Jan.	Feb.	Mar.	Apr.	May.	Jun.	Jul.	Aug.	Sep.	Oct	Nov.	Dec.
Mark	1	2	3	4	5	6	7	8	9	A	B	C

9.2 Detail of Lot Mark

- (1) Below label is attached on the backside of the LCD module. See Section 8.0: Outline Dimension.
- (2) The detail of Lot Mark is attached as below.
- (3) This is subject to change without prior notice.

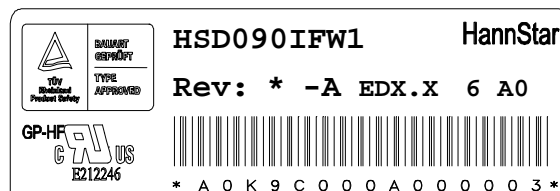

Document Title	HSD090IFW1-A Preliminary Specification	Page No.	22/24
Document No.	DC140-000***	Revision	1.0

10.0 PACKAGE SPECIFICATION

10.1 Packing form

- (1) Package quantity in one carton: 60 pieces.
- (2) Carton size: 548 mmx304 mmx365 mm.

10.2 Packing assembly drawings

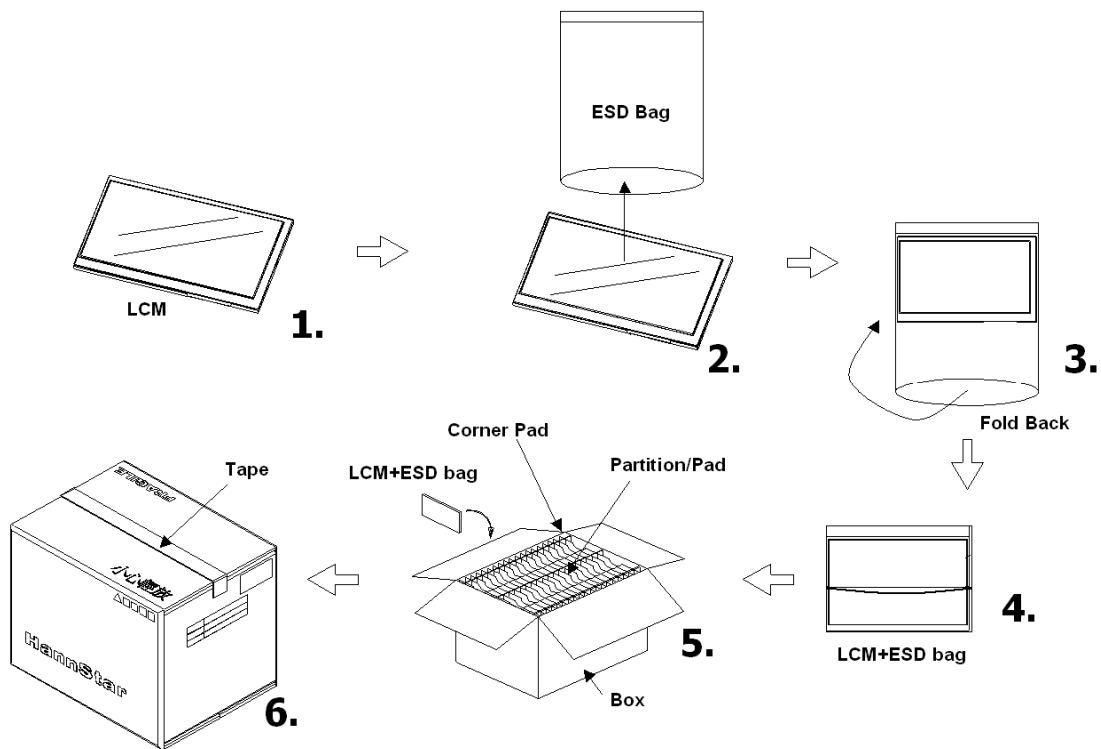

	Material	Notice
Box	Corrugated Paper Board	(AB Flute)
Partition/Pad	Corrugated Paper Board	(B Flute)
Corner Pad	Corrugated Paper Board	(AB Flute)
ESD bag	PE	

Document Title	HSD090IFW1-A Preliminary Specification	Page No.	23/24
Document No.	DC140-000***	Revision	1.0

11.0 GENERAL PRECAUTION

11.1 Use Restriction

This product is not authorized for use in life supporting systems, aircraft navigation control systems, military systems and any other application where performance failure could be life-threatening or otherwise catastrophic.

11.2 Disassembling or Modification

Do not disassemble or modify the module. It may damage sensitive parts inside LCD module, and may cause scratches or dust on the display. HannStar does not warrant the module, if customers disassemble or modify the module.

11.3 Breakage of LCD Panel

11.3.1. If LCD panel is broken and liquid crystal spills out, do not ingest or inhale liquid crystal, and do not contact liquid crystal with skin.

11.3.2. If liquid crystal contacts mouth or eyes, rinse out with water immediately.

11.3.3. If liquid crystal contacts skin or cloths, wash it off immediately with alcohol and rinse thoroughly with water.

11.3.4. Handle carefully with chips of glass that may cause injury, when the glass is broken.

11.4 Electric Shock

11.4.1. Disconnect power supply before handling LCD module.

11.4.2. Do not pull or fold the LED cable.

11.4.3. Do not touch the parts inside LCD modules and the fluorescent LED's connector or cables in order to prevent electric shock.

11.5 Absolute Maximum Ratings and Power Protection Circuit

11.5.1. Do not exceed the absolute maximum rating values, such as the supply voltage variation, input voltage variation, variation in parts' parameters, environmental temperature, etc., otherwise LCD module may be damaged.

11.5.2. Please do not leave LCD module in the environment of high humidity and high temperature for a long time.

11.5.3. It's recommended to employ protection circuit for power supply.

11.6 Operation

11.6.1 Do not touch, push or rub the polarizer with anything harder than HB pencil lead.

11.6.2 Use fingerstalls of soft gloves in order to keep clean display quality, when persons handle the LCD module for incoming inspection or assembly.

11.6.3 When the surface is dusty, please wipe gently with absorbent cotton or other soft material.



Document Title	HSD090IFW1-A Preliminary Specification	Page No.	24/24
Document No.	DC140-000***	Revision	1.0

11.6.4 Wipe off saliva or water drops as soon as possible. If saliva or water drops contact with polarizer for a long time, they may causes deformation or color fading.

11.6.5 When cleaning the adhesives, please use absorbent cotton wetted with a little petroleum benzine or other adequate solvent.

11.7 Mechanism

Please mount LCD module by using mounting holes arranged in four corners tightly.

11.8 Static Electricity

11.8.1 Protection film must remove very slowly from the surface of LCD module to prevent from electrostatic occurrence.

11.8.2 Because LCD module use CMOS-IC on circuit board and TFT-LCD panel, it is very weak to electrostatic discharge. Please be careful with electrostatic discharge. Persons who handle the module should be grounded through adequate methods.

11.9 Strong Light Exposure

The module shall not be exposed under strong light such as direct sunlight. Otherwise, display characteristics may be changed.

11.10 Disposal

When disposing LCD module, obey the local environmental regulations.